

ISSUE No.	DATE	DESCRIPTION	DRAWN	CHECKED	APPR
ISSUE-3	05-01-01	DIMENSION CHANGED FROM R65.49 15.98 & 37.69 TO R51.39, 14.0 & 35.0 ACCORDING TO PARTY'S REQUIREMENT	RANGA SWAMY		

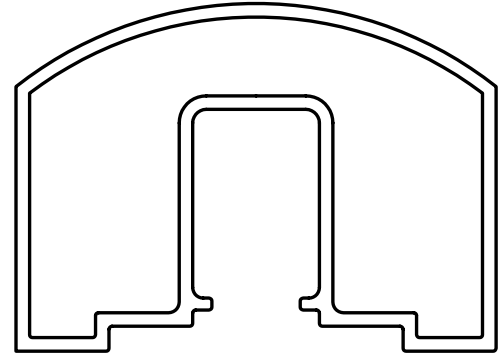

SCALE 1:1

NOTE:

1. GENERAL WALL THICKNESS 1.79 mm

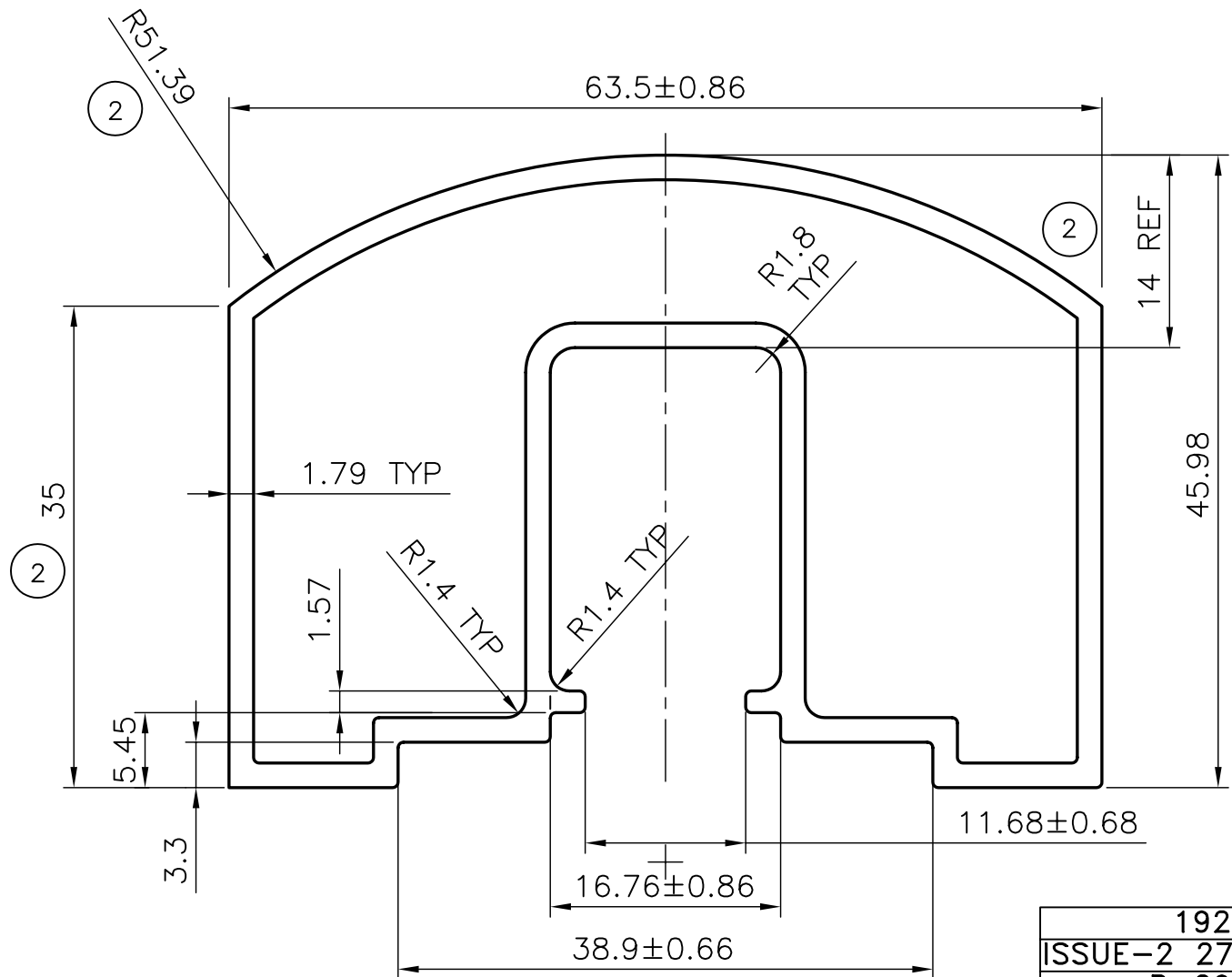

19233
ISSUE-2 2776
P-2985

 SYMBOL OF QUALITY AN ISO 9002 COMPANY	JINDAL ALUMINIUM LTD. BANGALORE-560073 (INDIA)		NAME	DATE
			DRAWN	RANGASWAMY 05-01-01
1. ALL DIMENSIONS ARE IN mm. 2. ROUND OFF ALL SHARP CORNERS WITH 0.40 mm. 3. TOLERANCES WILL BE AS PER I.S. 6477-1983 UNLESS OTHERWISE SPECIFIED			CHECKED	
			APPROVED	
			SCALE	2:1
PARTY'S NAME			WEIGHT kg/m	1.268
PARTY'S DRAWING No.	AS PER DRAWING (00101)		SECTION No.	19233
ALLOY & TEMPER	6060 T5	LENGTH	5500 mm	DRAWING No. 19233
DESCRIPTION	RECTANGULAR TOP RAIL			