

P-3199-2

2795

19234

NOTE :-
GENERAL WALL THICKNESS=1.79mm

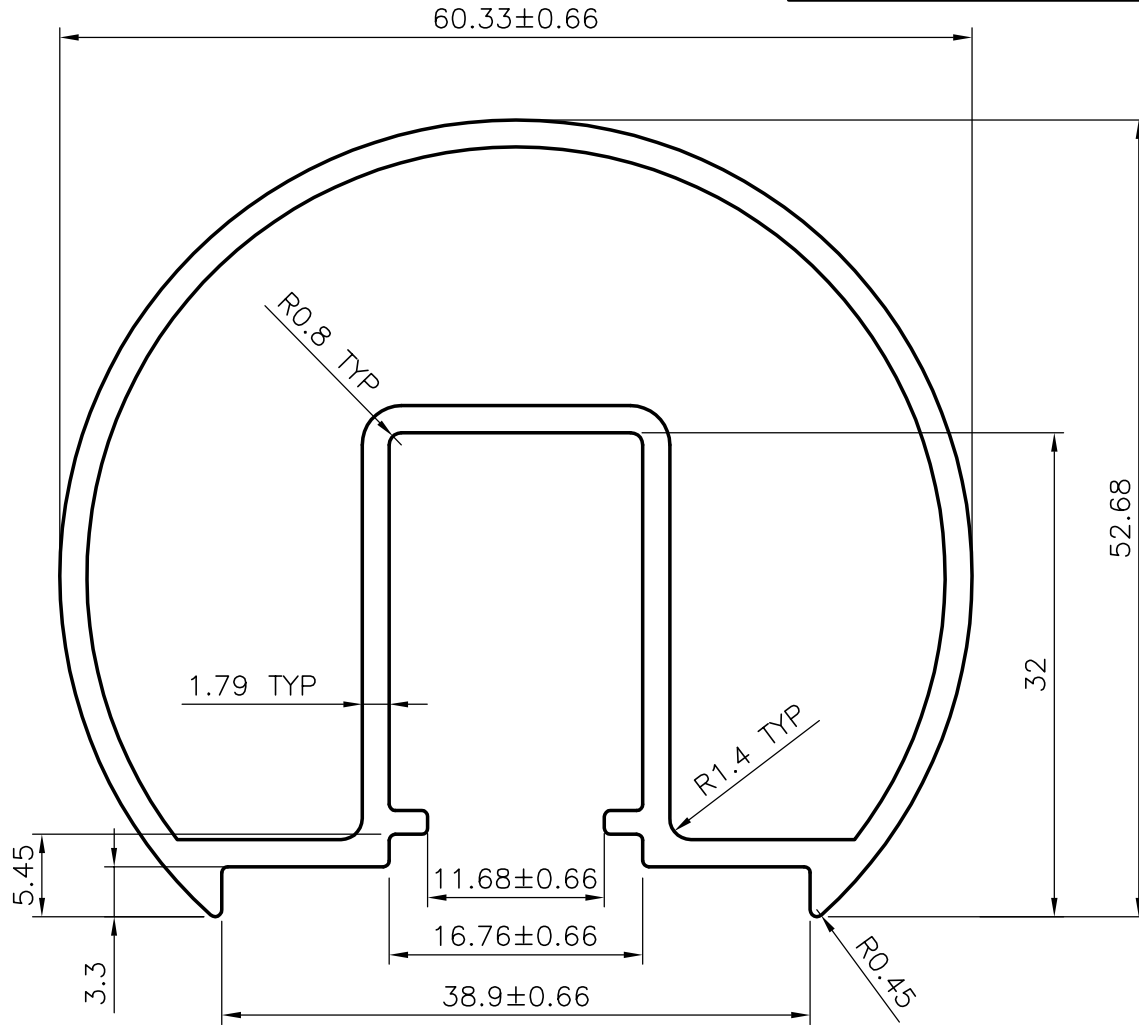
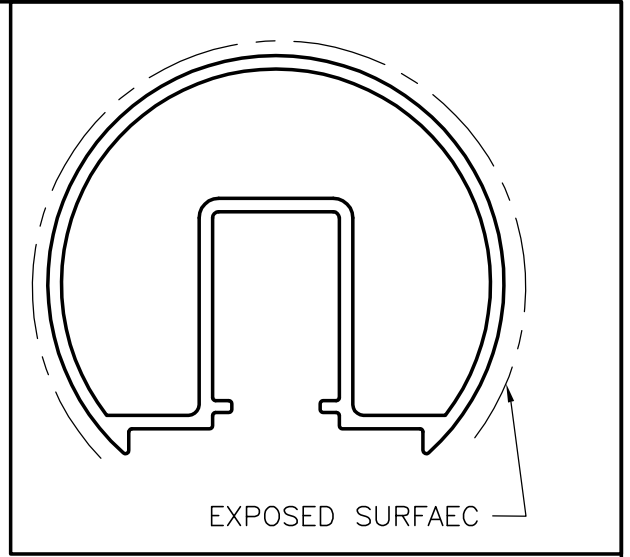

SYMBOL OF QUALITY
AN ISO 9002 COMPANY

JINDAL ALUMINIUM LTD.
BANGALORE-560073 (INDIA)

NAME DATE

DRAWN RAGHAVENDRA 03-05-01

CHECKED

APPROVED

SCALE 2:1 & 1:1

WEIGHT kg/m 1.191

PERIMETER 256.75mm

SECTION No. 19234

DRAWING No. 19234

1. ALL DIMENSIONS ARE IN mm.
2. ROUND OFF ALL SHARP CORNERS WITH 0.40 mm.
3. TOLERANCES WILL BE AS PER IS 6477-1983 UNLESS OTHERWISE SPECIFIED

PARTY'S NAME PROSOURCE INDUSTRIAL SOLUTIONS ,. CANADA

PARTY'S DRAWING No. AS PER DRAWING

ALLOY & TEMPER 6060-T5

DESCRIPTION ROUND TOP RAIL