

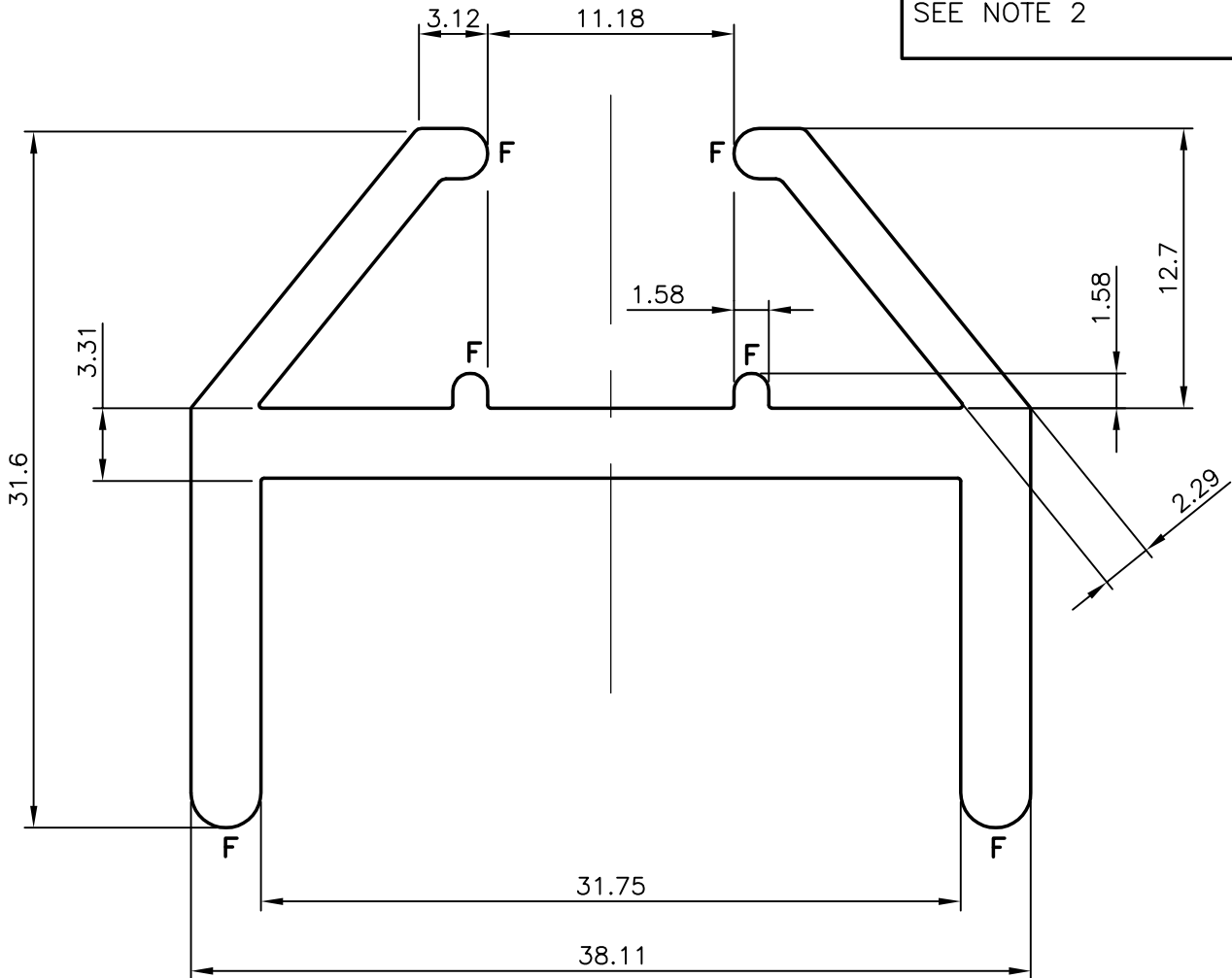

P-3190
3965
19235

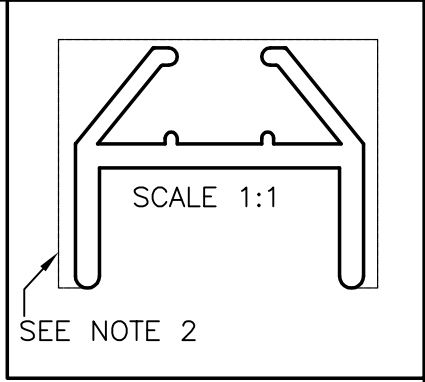

NOTE:-

1. F-FULL RADIUS (06PLACES)
2. EXPOSED SURFACE GOOD FINISH REAQUIRED

 SYMBOL OF QUALITY AN ISO 9001 COMPANY	JINDAL ALUMINIUM LTD. BANGALORE-560073 (INDIA)	NAME	DATE
		DRAWN	PRASANN.H 18-12-2006
		CHECKED	
		APPROVED	
1. ALL DIMENSIONS ARE IN mm. 2. ROUND OFF ALL SHARP CORNERS WITH 0.40 mm. 3. TOLERANCES WILL BE AS PER IS:3965-1981 UNLESS OTHERWISE SPECIFIED		SCALE	3:1
		AREA mm ²	303.504
		PERIMETER mm.	214.055
		WEIGHT kg/m	0.819
PARTY'S NAME	PROSOURCE INDUSTRIAL SOLUTION,. CANADA	DRAWING No.	SECTION No.
PARTY'S DRAWING No.	AS PER SAMPLE	P-3190	-
ALLOY & TEMPER	6063 T5	3965	3965
DESCRIPTION	-	19235	19235