

P-3616

3966

19236

MATCHING SECTION
SCALE 1:1

EXPOSED
SURFACE

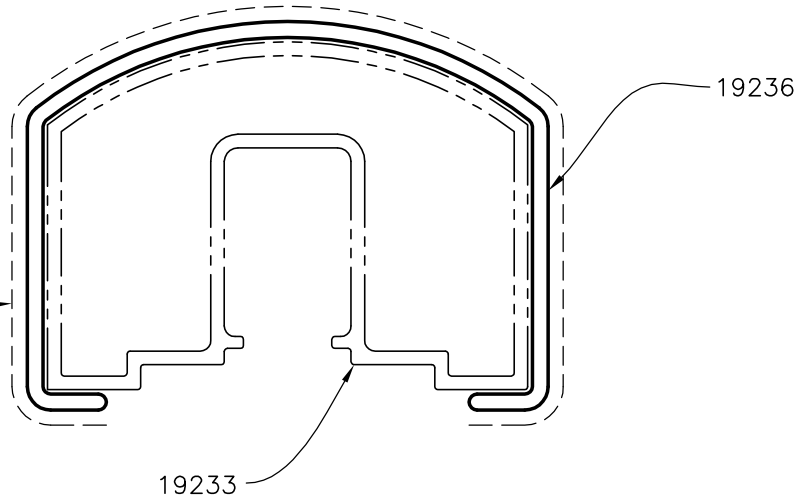

IMPORTANT
DIMENSION

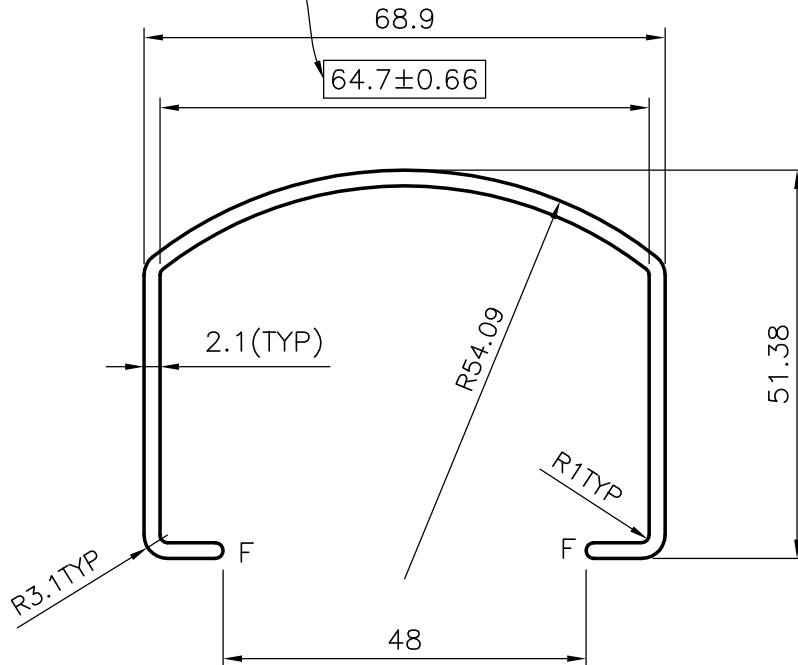

GENERAL WALL THICKNESS = 2.1mm
F = FULL RADII (2 PLACES)



SYMBOL OF QUALITY
AN ISO 9002 COMPANY

JINDAL ALUMINIUM LTD.
BANGALORE-560073 (INDIA)

NAME DATE

DRAWN RAGHAVENDRA 27-10-01

CHECKED

APPROVED

SCALE 1:1

WEIGHT kg/m 0.926

PERIMETER 330.23mm

SECTION No. 19236

DRAWING No. 19236

1. ALL DIMENSIONS ARE IN mm.
2. ROUND OFF ALL SHARP CORNERS WITH 0.40 mm.
3. TOLERANCES WILL BE AS PER IS 3965-1981 UNLESS OTHERWISE SPECIFIED

PARTY'S NAME PROSOURCE INDUSTRIAL SOLUTIONS ,. CANADA

PARTY'S DRAWING No. AS PER DRAWING

ALLOY & TEMPER 6060 T5

DESCRIPTION -