

P-7891-2

19240

MATCHING SECTION

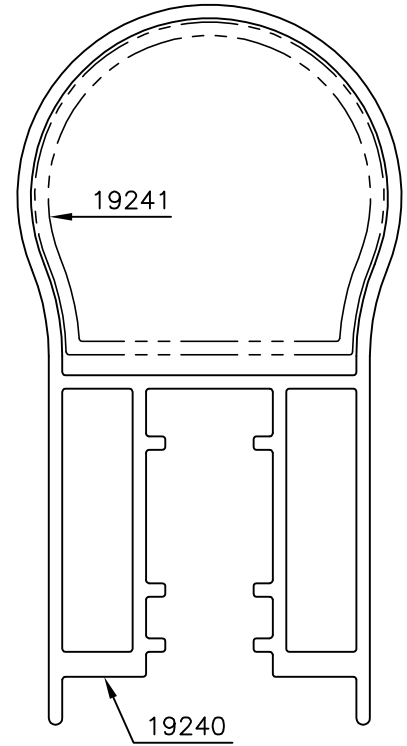
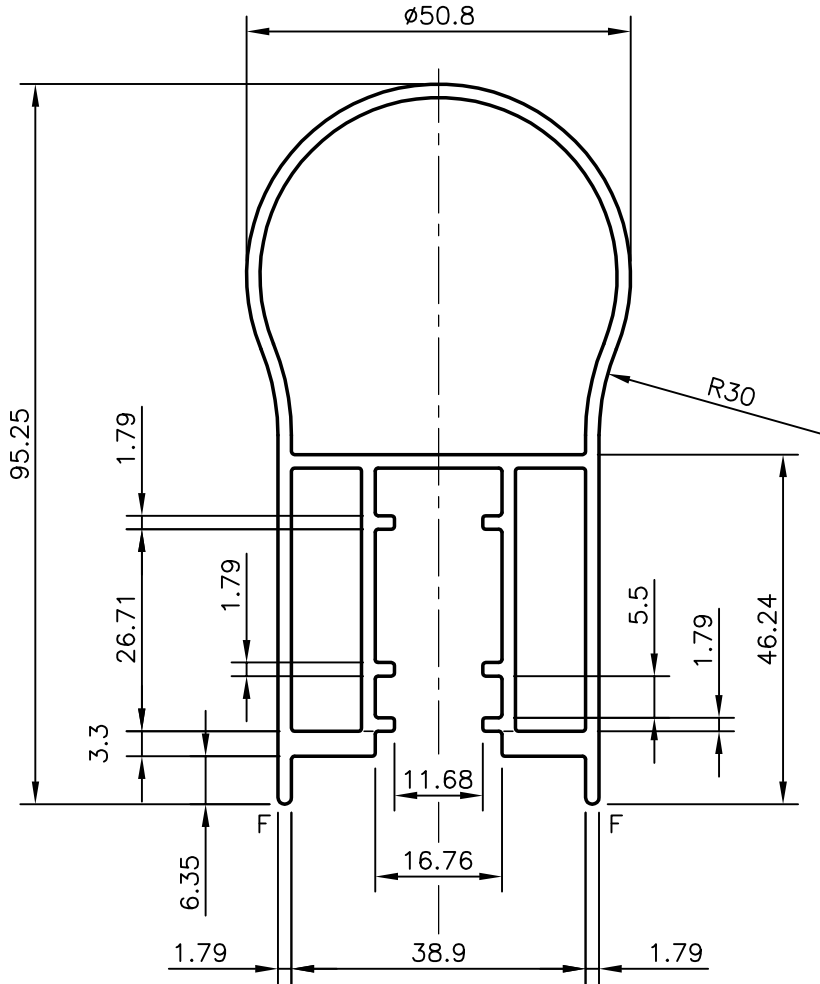

F = FULL RADIUS (2 PLACES)
 UNSPECIFIED WALL THICKNESS = 1.79 mm



SYMBOL OF QUALITY
 AN ISO 9001 COMPANY

JINDAL ALUMINIUM LTD.
 BANGALORE-560073 (INDIA)

	NAME	DATE
DRAWN	PRASANNA.H	29-07-2008
CHECKED		
APPROVED		

1. ALL DIMENSIONS ARE IN mm.
2. ROUND OFF ALL SHARP CORNERS WITH 0.40 mm.
3. TOLERANCES WILL BE AS PER BS:EN-755 UNLESS OTHERWISE SPECIFIED

SCALE	1:1
AREA mm ²	684.093
PERIMETER mm.	375.757
WEIGHT kg/m	1.847

PARTY'S NAME	PROSOURCE INDUSTRIAL SOLUTIONS, CANADA
PARTY'S DRAWING No.	AS PER DRAWING
ALLOY & TEMPER	6063 T5
DESCRIPTION	MISC. SECTION (HAND RAIL)

DRAWING No.	SECTION No.
P-7891-2	-
19240	19240