

P-9931-1

19242

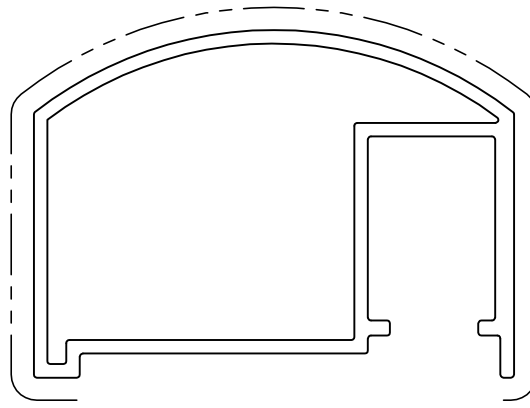

EXPOSED SURFACE

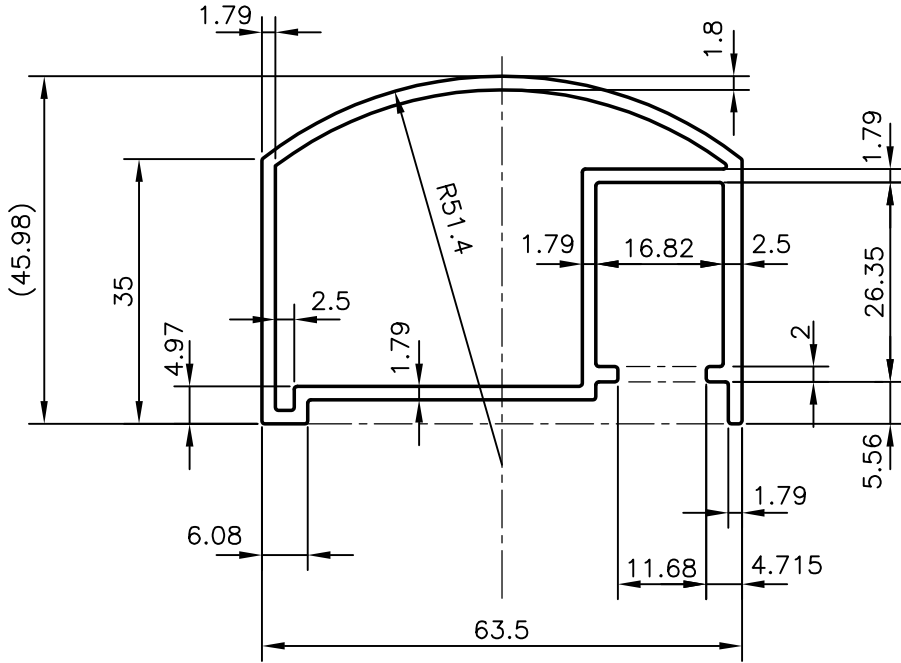

SYMBOL OF QUALITY
AN ISO 9001 COMPANY

JINDAL ALUMINIUM LTD.
BANGALORE-560073 (INDIA)

	NAME	DATE
DRAWN	J.P.KAUSHIK	30-03-2010
CHECKED		
APPROVED	J.N. RAI	16-04-2010
SCALE		1:1
AREA mm ²		436.698
PERIMETER mm.		273.245
WEIGHT kg/m		1.179
DRAWING No.	SECTION No.	
P-9931-1	-	
19242	19242	

1. ALL DIMENSIONS ARE IN mm.
2. ROUND OFF ALL SHARP CORNERS WITH 0.40 mm.
3. TOLERANCES WILL BE AS PER BS:EN-755 UNLESS OTHERWISE SPECIFIED

PARTY'S NAME	PROSOURCE INDUSTRIAL SOLUTIONS, CANADA
PARTY'S DRAWING No.	AS PER DRAWING
ALLOY & TEMPER	6063 T5
DESCRIPTION	HAND RAIL SECTION