

P-11798
S3351
19243

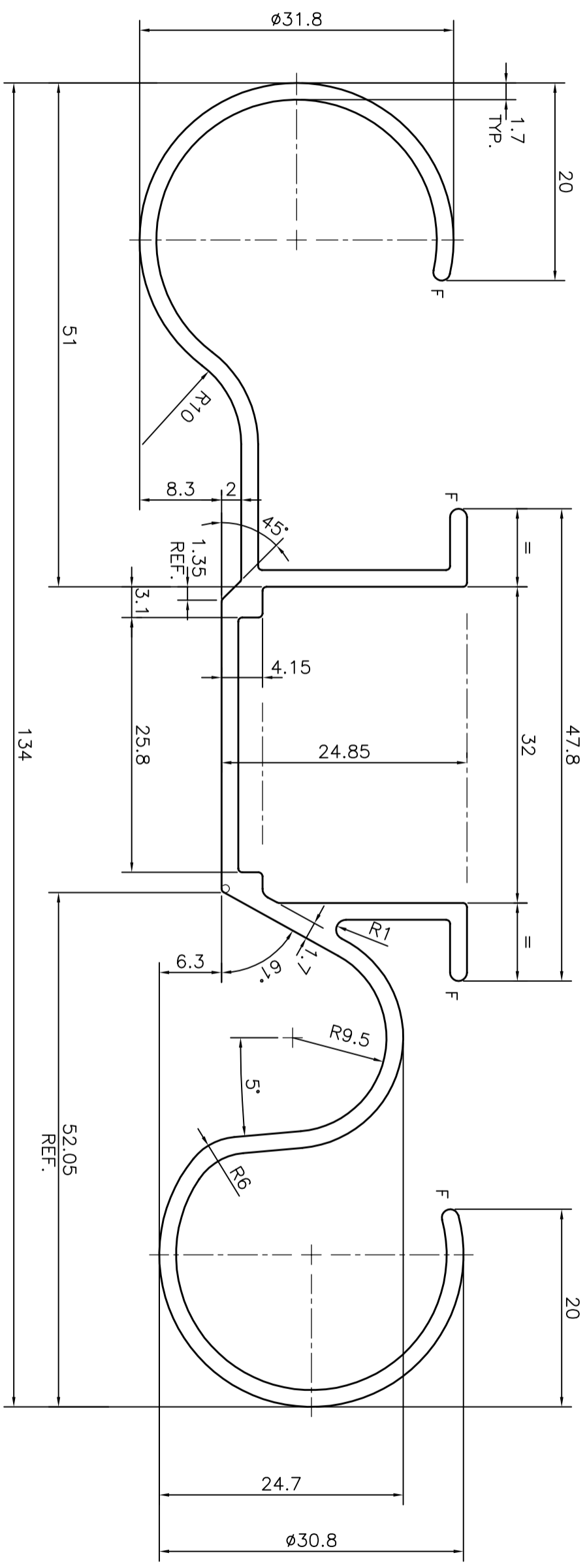

F = FULL RADIUS (4 PLACES)

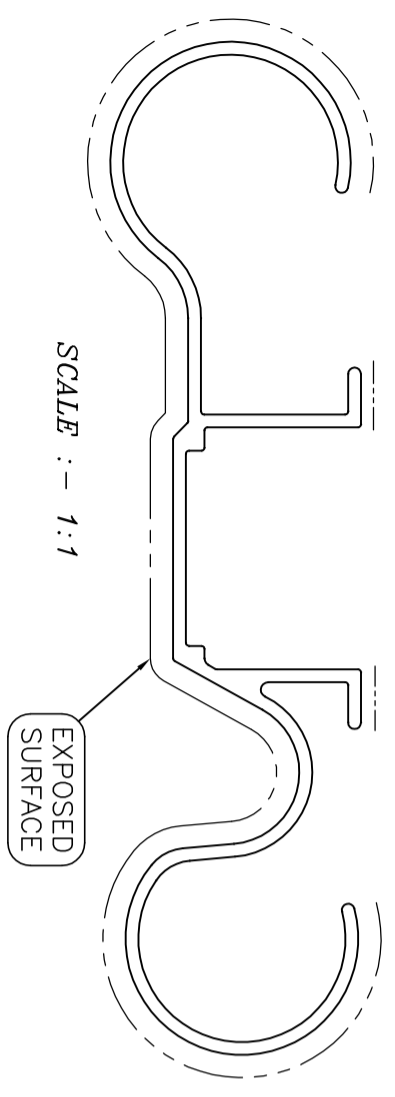

SCALE :- 1:1

EXPOSED SURFACE

 SYMBOL OF QUALITY AN ISO 9001 COMPANY		JINDAL ALUMINIUM LTD. BANGALORE-560073 (INDIA)	
1. ALL DIMENSIONS ARE IN mm. 2. ROUND OFF ALL SHARP CORNERS WITH 0.40 mm. 3. TOLERANCES WILL BE AS PER IS:3965-1981, UNLESS OTHERWISE SPECIFIED			
PARTY'S NAME	V.G.SALES, NEW DELHI		
PARTY'S DRAWING No.	AS PER SAMPLE		
ALLOY & TEMPER	6063 T6		
DESCRIPTION	HANDRAIL SECTION		
DRAWN	NAME	DATE	
CHECKED	PARVESH	05-06-2012	
APPROVED	S.S.GARG	12-06-2012	
SCALE		2:1	
AREA	mm ²	491.597	
PERIMETER	mm.	559.018	
WEIGHT	kg/m	1.327	
DRAWING No.		SECTION No.	
P-11798		-	
S3351		S3351	
19243		19243	