

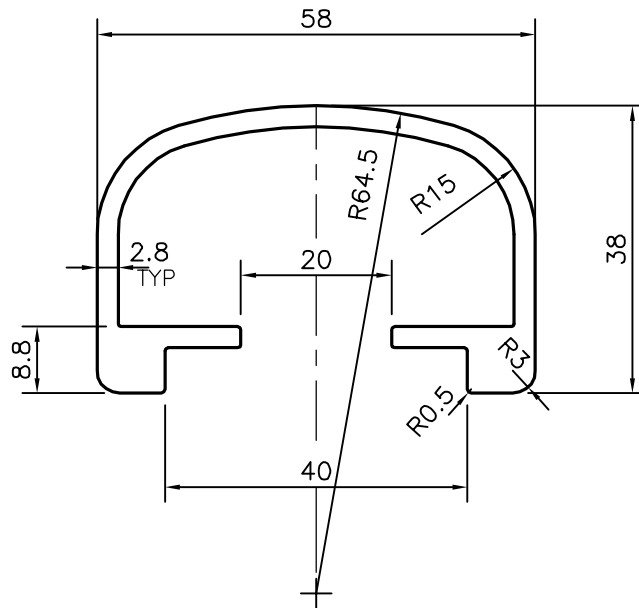

P-15447
S4810
19244



 SYMBOL OF QUALITY AN ISO 9002 COMPANY	JINDAL ALUMINIUM LTD. BANGALORE-560073 (INDIA)	NAME		DATE	
		DRAWN	J.P.KAUSHIK	19-12-2015	
1. ALL DIMENSIONS ARE IN mm. 2. ROUND OFF ALL SHARP CORNERS WITH 0.40 mm. 3. TOLERANCES WILL BE AS PER IS:3965-1981 UNLESS OTHERWISE SPECIFIED		CHECKED			
		APPROVED	S.S.GARG	28-12-2015	
PARTY'S NAME		FULL SPACE INTERIORS, MUMBAI		SCALE	1:1
		PARTY'S DRAWING No.		FSI-AL-DIE-01	AREA mm ²
ALLOY & TEMPER		6063 T6		PERIMETER mm.	292.164
		DESCRIPTION		HAND RAIL SECTION	WEIGHT kg/m
		DRAWING No.		P-15447	SECTION No.
				S4810	S4810
				19244	19244