

P-15622

S4857

19246

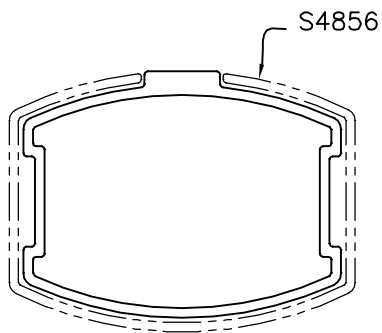
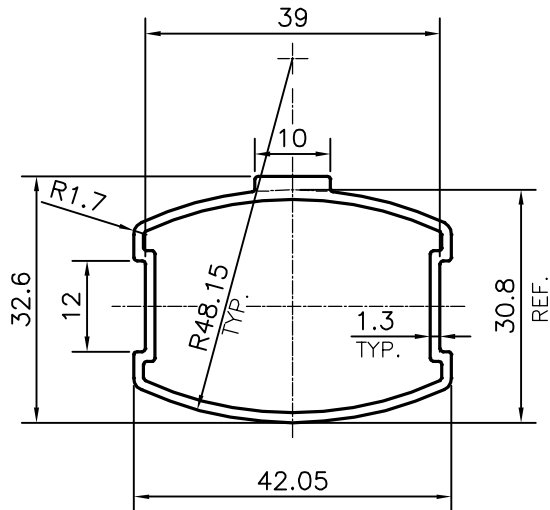

SYMBOL OF QUALITY
AN ISO 9001 COMPANY

JINDAL ALUMINIUM LTD.
BANGALORE-560073 (INDIA)

	NAME	DATE
DRAWN	PARVESH	20-02-2016
CHECKED		
APPROVED	S.S.GARG	23-02-2016
SCALE		1:1
AREA mm ²		188.342
PERIMETER mm.		136.582
WEIGHT kg/m		0.509
DRAWING No.	SECTION No.	
P-15622	-	
S4857	S4857	
19246	19246	

1. ALL DIMENSIONS ARE IN mm.
2. ROUND OFF ALL SHARP CORNERS WITH 0.40 mm.
3. TOLERANCES WILL BE AS PER IS:6477-1983 , UNLESS OTHERWISE SPECIFIED

PARTY'S NAME	S.S. FABTECH, BANGALORE
PARTY'S DRAWING No.	AS PER SAMPLE
ALLOY & TEMPER	HE9 WP
DESCRIPTION	HAND RAIL SECTION