

4431  
19367

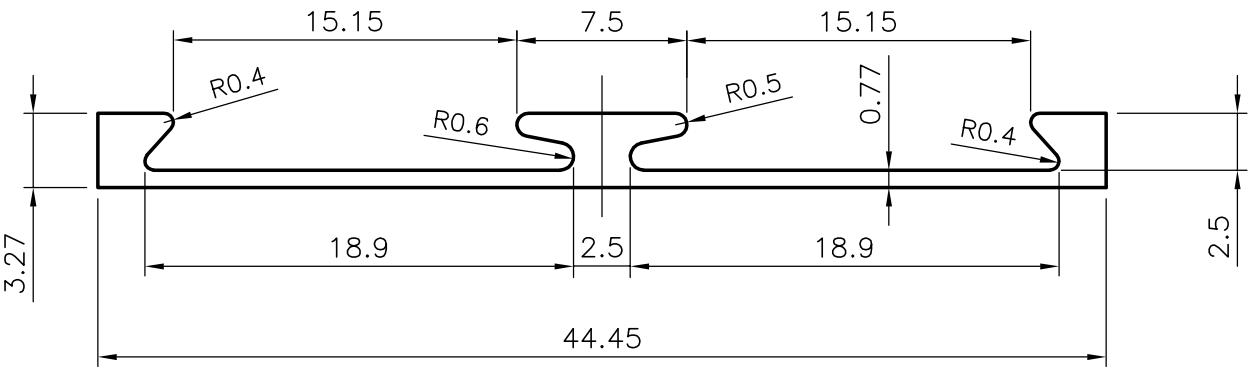

SCALE 1:1



GENERAL WALL THICKNESS = 0.77mm

3658 mm, LONG PIECES IN 100 Kgs = 170 (AVERAGE)

 SYMBOL OF QUALITY AN ISO 9002 COMPANY	<b>JINDAL ALUMINIUM LTD.</b> BANGALORE-560073 (INDIA)	NAME		DATE
		DRAWN	RAGHAVENDRA	09-03-2004
		CHECKED		
1. ALL DIMENSIONS ARE IN mm. 2. ROUND OFF ALL SHARP CORNERS WITH 0.40 mm. 3. TOLERANCES WILL BE AS PER IS:3965-1981 UNLESS OTHERWISE SPECIFIED		SCALE		3:1
PARTY'S NAME		GENERAL CATEGORY		AREA mm <sup>2</sup>
				59.7
PARTY'S DRAWING No.		GENERAL CATEGORY		PERIMETER mm.
				115.72
ALLOY & TEMPER		GENERAL CATEGORY		WEIGHT kg/m
				0.161
DESCRIPTION		GENERAL CATEGORY		DRAWING No.
				4431
				SECTION No.
				19367
				19367