

4432
19368

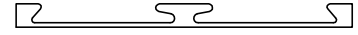

SCALE 1:1

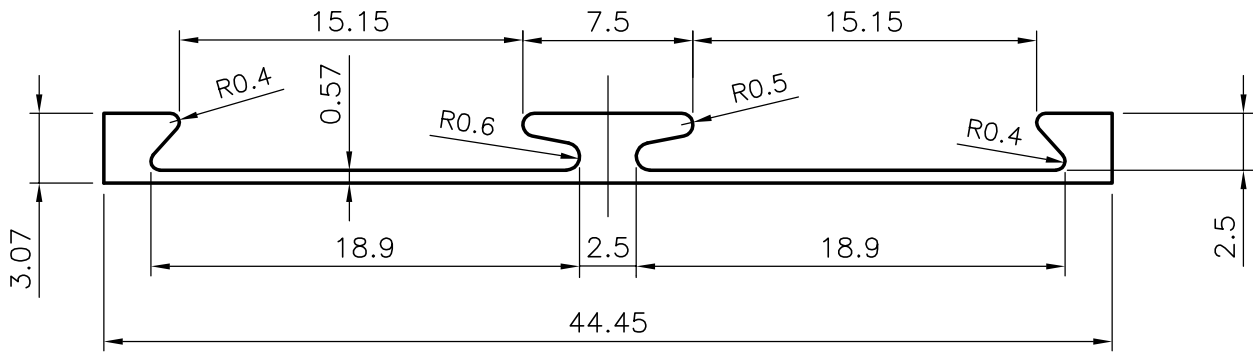

GENERAL WALL THICKNESS = 0.57mm

3658 mm, LONG PIECES IN 100 Kgs = 200 (AVERAGE)

 SYMBOL OF QUALITY AN ISO 9002 COMPANY	JINDAL ALUMINIUM LTD. BANGALORE-560073 (INDIA)	NAME		DATE
		DRAWN	RAGHAVENDRA	09-03-2004
1. ALL DIMENSIONS ARE IN mm. 2. ROUND OFF ALL SHARP CORNERS WITH 0.40 mm. 3. TOLERANCES WILL BE AS PER IS:3965-1981 UNLESS OTHERWISE SPECIFIED		CHECKED		
		APPROVED		
PARTY'S NAME GENERAL CATEGORY		SCALE		3:1
		AREA mm ²		50.81
PARTY'S DRAWING No. NIL		PERIMETER mm.		115.32
		WEIGHT kg/m		0.137
ALLOY & TEMPER HE9 WP		DRAWING No.		SECTION No.
		4432		4432
DESCRIPTION GLAZING SECTION		19368		19368