

4433
14607
19369

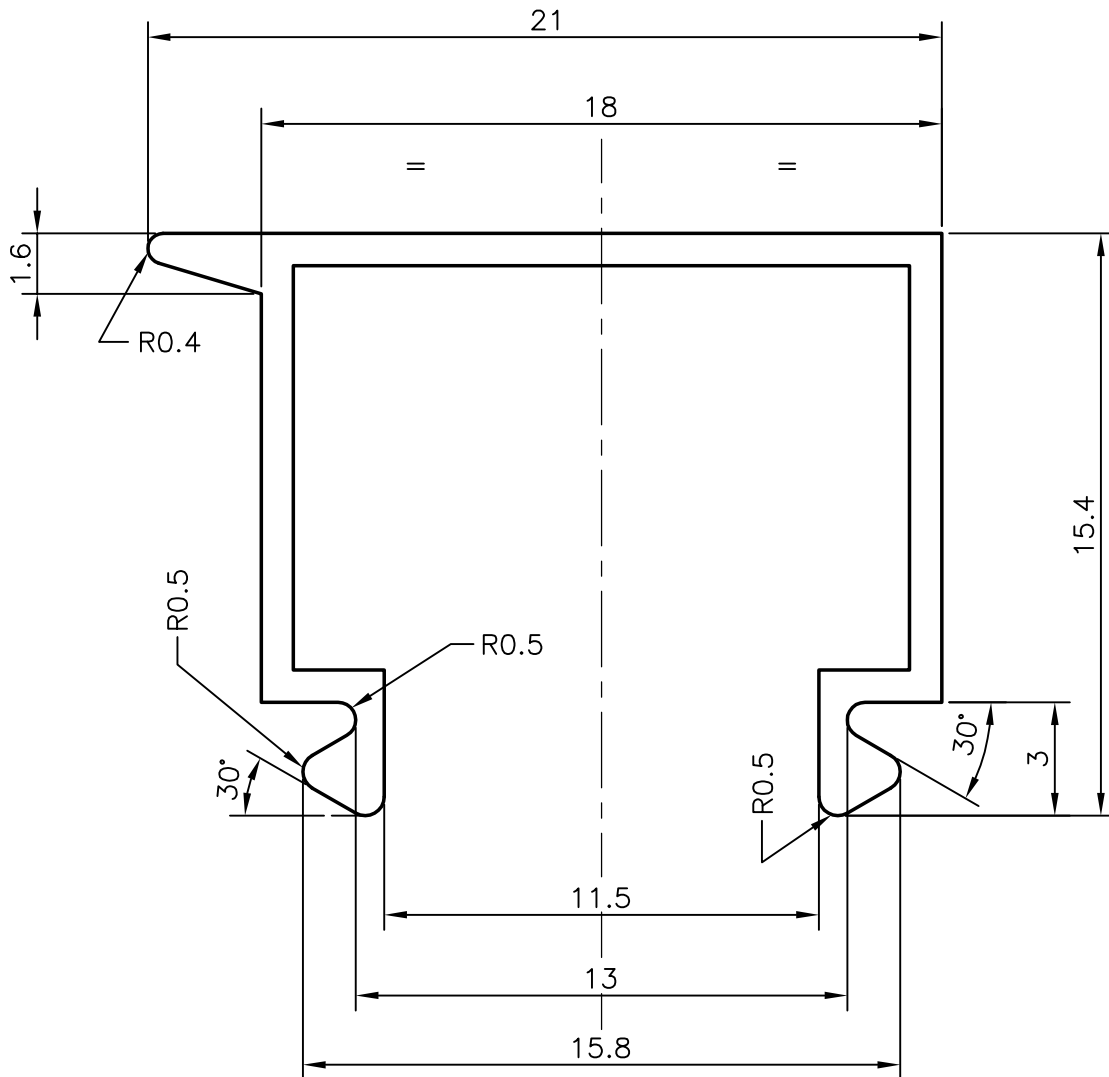
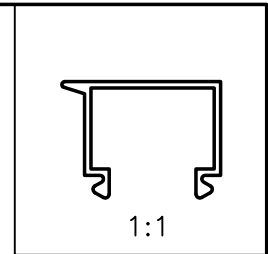

GENERAL WALL THICKNESS :- 0.85 mm.
NO. OF PIECES IN 100 kgs. :- 200 (AVERAGE)
SUITABLE FOR SECTION NO. :- 8802,8803,8804,8937

JINDAL ALUMINIUM LTD. BANGALORE-560073			NAME	DATE
		DRAWN	R.D.Sharma	21-03-98
1. ALL DIMENSIONS ARE IN mm. 2. ROUND OFF ALL SHARP CORNERS WITH 0.4 mm. 3. TOLERANCES WILL BE AS PER IS: 3965-1981 ,UNLESS OTHERWISE SPECIFIED		CHECKED		
		APPROVED		
		SCALE	5:1	
PARTY'S NAME	GENERAL CATEGORY	WEIGHT kg/m	0.137	
PARTY'S DRAWING No.	NIL	SECTION No.	19369	
ALLOY & TEMPER	HE9 WP	DRAWING No.	19369	
LENGTH	3658 mm.			
DESCRIPTION	GLAZING CLIP			