

| |
|-------|
| 4440 |
| 19376 |
| - |
| - |

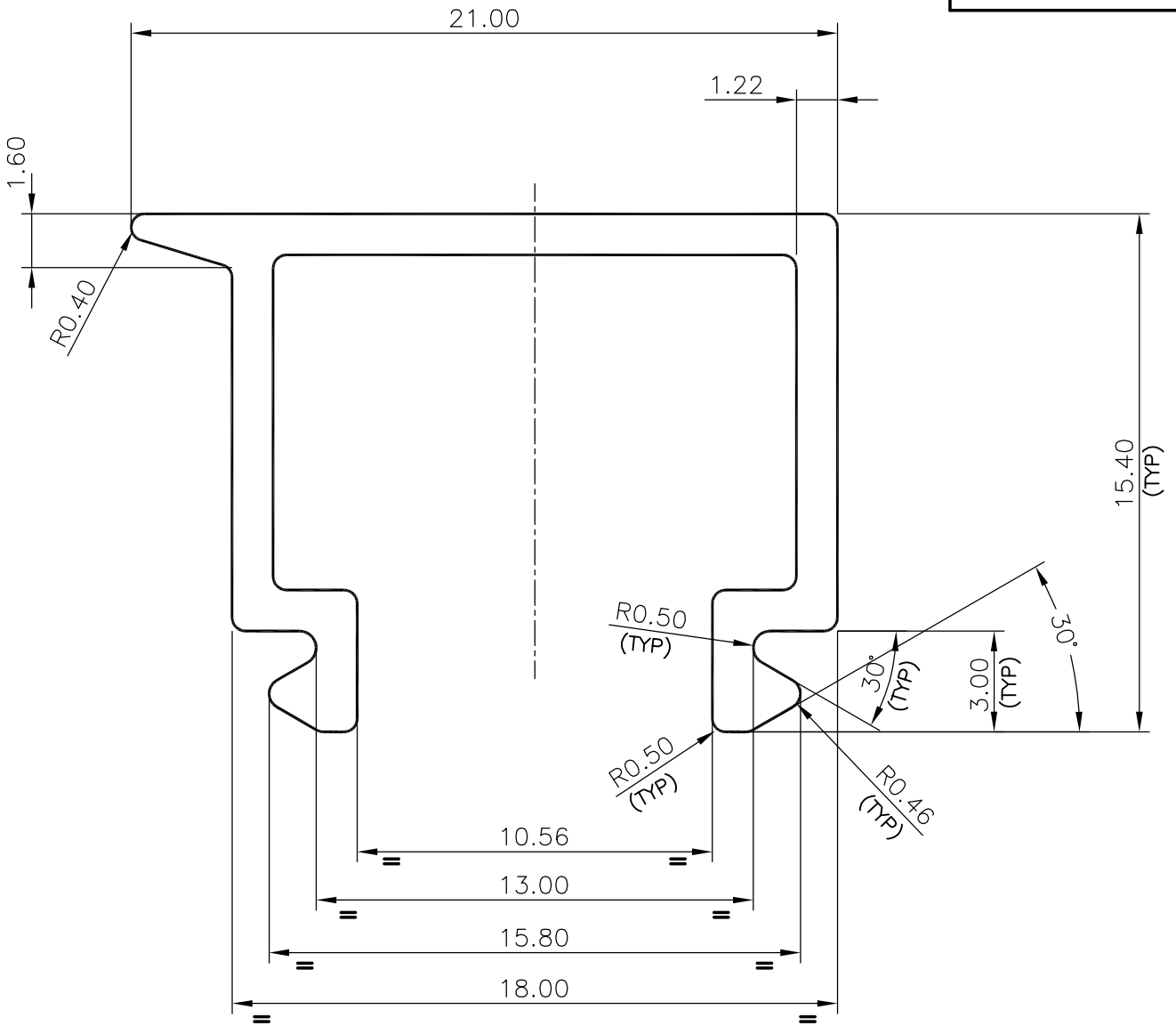
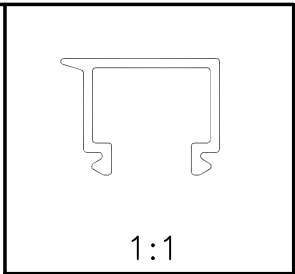

UNSPECIFIED WALL THICKNESS = 1.22 mm
MATCHING SEC No ; 8805, 8803, 8804.

| | | | |
|---|-------------------------------------|-------------|---------------------|
| JINDAL ALUMINIUM LTD. BANGALORE-560073 | | NAME | DATE |
| | | DRAWN | P,KULKARNI 18-02-99 |
| 1. ALL DIMENSIONS ARE IN mm. 2. ROUND OFF ALL SHARP CORNERS WITH 0.4 mm. 3. TOLERANCES WILL BE AS PER IS: 3965-1981 ,UNLESS OTHERWISE SPECIFIED | | CHECKED | |
| | | APPROVED | |
| | | SCALE | 5:1 |
| PARTY'S NAME | TRIDENT INDUSTRIAL PRODUCTS, B'LORE | WEIGHT kg/m | 0.188 |
| PARTY'S DRAWING No. | AS PER SPECIFICATION | SECTION No. | 19376 |
| ALLOY & TEMPER | HE9 WP | DRAWING No. | 19376 |
| LENGTH | 3658 mm | | |
| DESCRIPTION | GLAZING CLIP | | |