

4442

19378

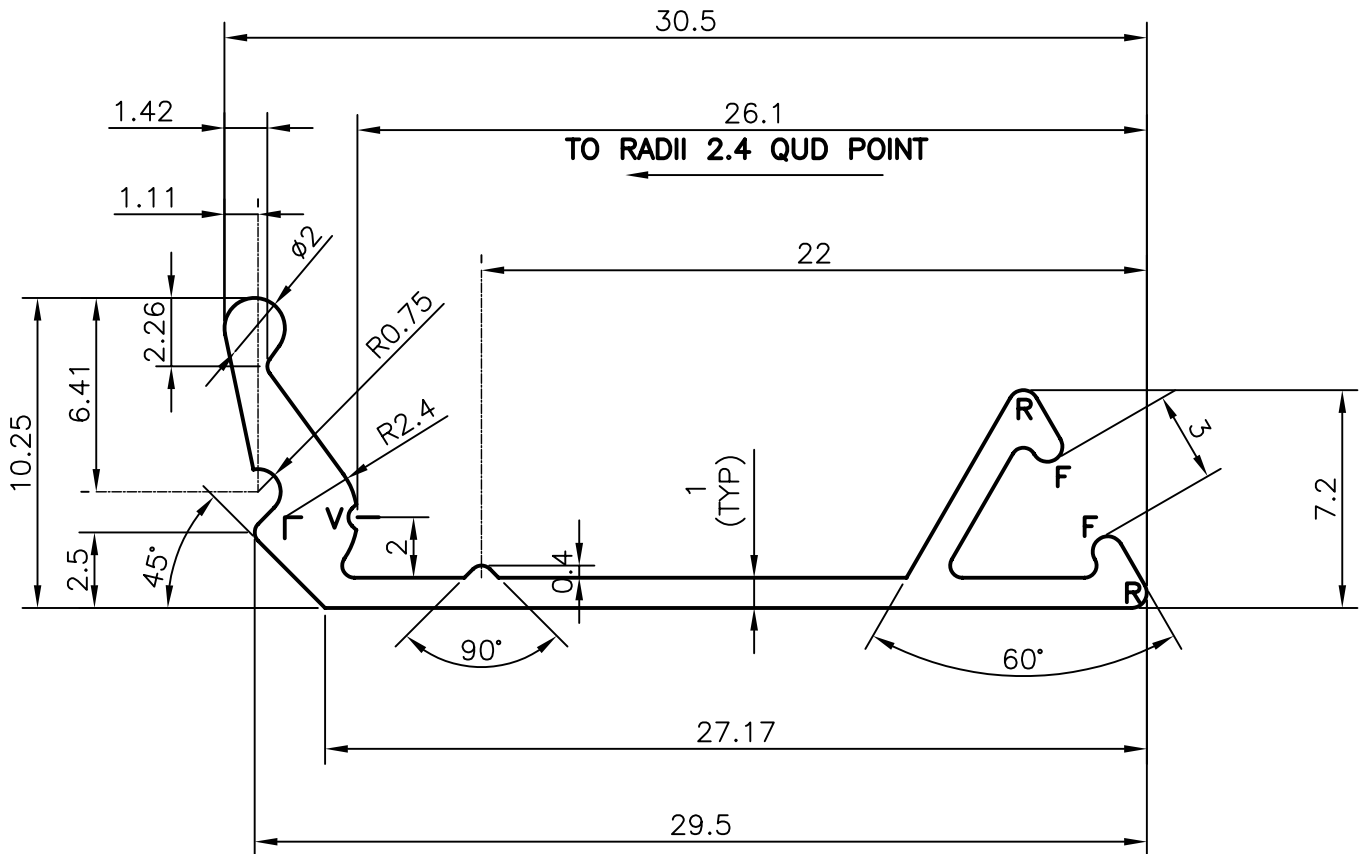

SCALE 1:1



GENERAL WALL THICKNESS 1.00 mm

R = RADII 0.50 (2-PLACE)

F = RADII FULL (2-PLACE)

V = GROOVE 0.30x90° (1-PLACE) INCLUDING R0.30

SYMBOL OF QUALITY
AN ISO 9001 COMPANY**JINDAL ALUMINIUM LTD.**
BANGALORE-560073 (INDIA)

	NAME	DATE
DRAWN	PRASANNA.H.	13-12-2006
CHECKED		
APPROVED		

1. ALL DIMENSIONS ARE IN mm.
2. ROUND OFF ALL SHARP CORNERS WITH 0.40 mm.
3. TOLERANCES WILL BE AS PER IS:3965-1981 UNLESS OTHERWISE SPECIFIED

SCALE	4:1
AREA mm ²	57.512
PERIMETER mm.	95.295
WEIGHT kg/m	0.155

PARTY'S NAME	RADHA SOAMI SATSANG BEAS, BEAS.
PARTY'S DRAWING No.	AS PER SAMPLE (B.M. 20012)
ALLOY & TEMPER	HE9 WP
DESCRIPTION	GLAZING CLIP

DRAWING No.	SECTION No.
4442	-
19378	19378
-	-