

4444

19380

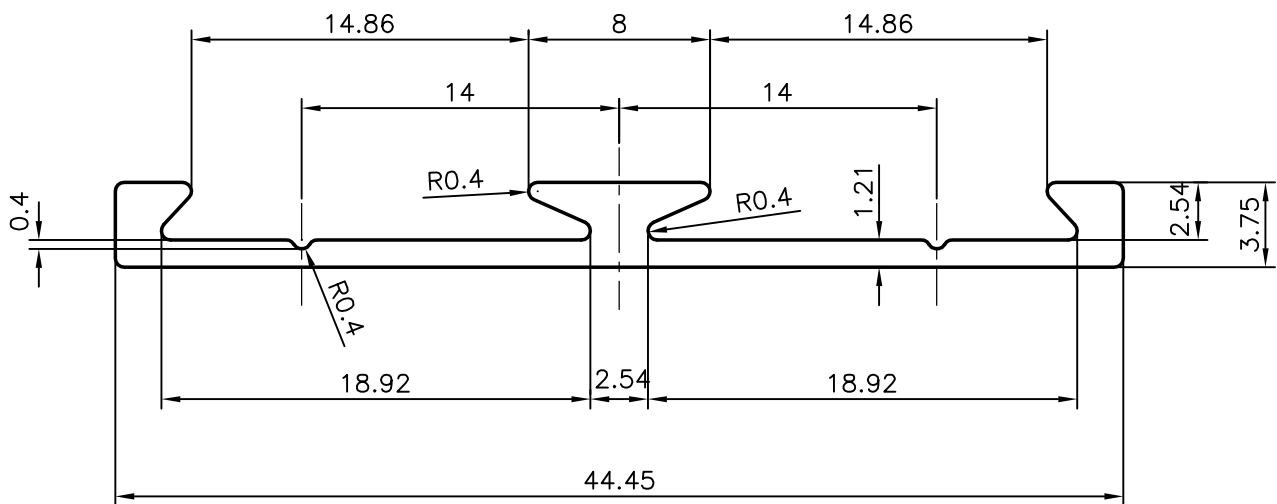

1:1



GENERAL WALL THICKNESS = 1.21 mm

3658 mm. LONG PIECES IN 100 kgs:- 125 (AVERAGE)



SYMBOL OF QUALITY
AN ISO 9001 COMPANY

JINDAL ALUMINIUM LTD.
BANGALORE-560073 (INDIA)

	NAME	DATE
DRAWN	MALINGAPPA	20-11-2005
CHECKED		
APPROVED		

1. ALL DIMENSIONS ARE IN mm.
2. ROUND OFF ALL SHARP CORNERS WITH 0.50 mm.
3. TOLERANCES WILL BE AS PER IS:3965-1981 UNLESS OTHERWISE SPECIFIED

SCALE	3:1
AREA mm ²	80.195
PERIMETER mm.	117.493
WEIGHT kg/m	0.216

PARTY'S NAME

-

PARTY'S DRAWING No.

LIGHTER OF 4408

ALLOY & TEMPER

HE9 WP

DESCRIPTION

GLAZING CLIP

DRAWING No.

4444
19380

SECTION No.

4444
19380