

P-4059

4446 1-2

19382

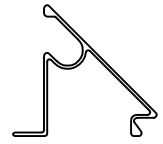

1:1

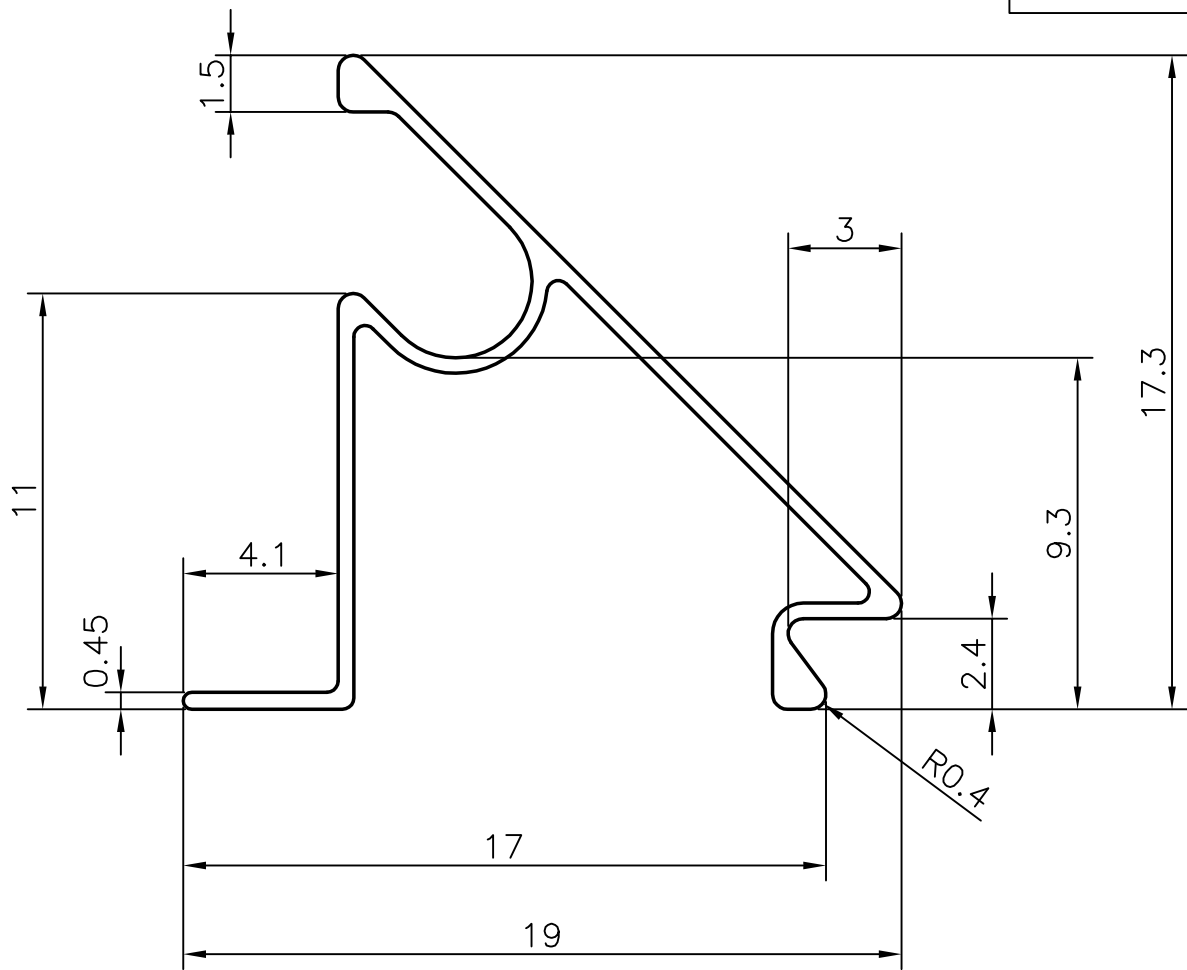

1. GENERAL WALL THICKNESS :- 0.41 mm. (2)

2. 3658 mm. LONG PIECES IN 100 kg :- 450 (AVERAGE) (2)

ISSUE-2

1. GENERAL WALL THICKNESS CHANGED FROM 0.36 mm. TO 0.41 mm.
2. NO. OF PIECES CHANGED FROM 500 TO 450
3. WEIGHT kg/m CHANGED FROM 0.055 TO 0.061



SYMBOL OF QUALITY
AN ISO 9002 COMPANY

JINDAL ALUMINIUM LTD.
BANGALORE-560073 (INDIA)

	NAME	DATE
DRAWN	R.D.Sharma	15-05-03
CHECKED		
APPROVED		

1. ALL DIMENSIONS ARE IN mm.
2. ROUND OFF ALL SHARP CORNERS WITH 0.40 mm.
3. TOLERANCES WILL BE AS PER IS: 6477-1983 UNLESS OTHERWISE SPECIFIED

SCALE	1:1 & 5:1
AREA mm ²	22.5
PERIMETER mm.	96.2
WEIGHT kg/m	0.061 (2)
SECTION No.	19382
DRAWING No.	19382

PARTY'S NAME	GENERAL CATEGORY, COCHIN MARKET
PARTY'S DRAWING No.	AS PER SAMPLE
ALLOY & TEMPER	HE9 WP
DESCRIPTION	GLAZING CLIP