

P-4694

4449

19385

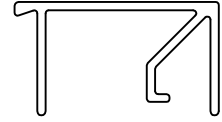

SCALE 1:1

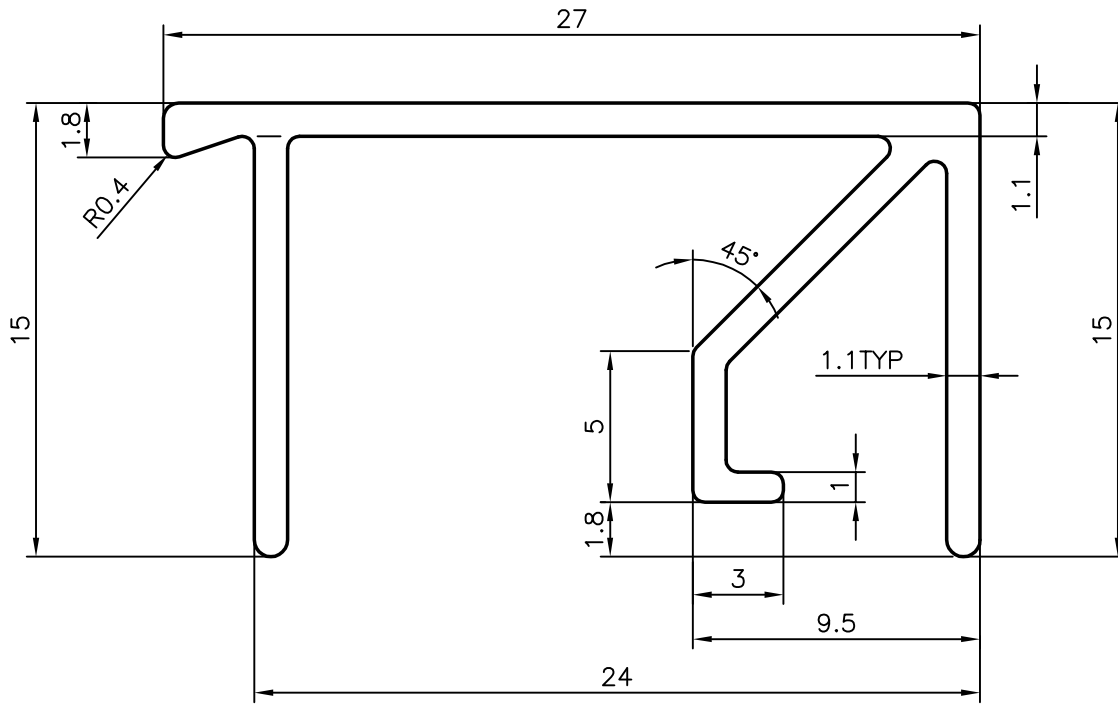

GENERAL WALL THICKNESS = 1.1mm



SYMBOL OF QUALITY
AN ISO 9002 COMPANY

JINDAL ALUMINIUM LTD.
BANGALORE-560073 (INDIA)

	NAME	DATE
DRAWN	RAGHAVENDRA	19-03-2004
CHECKED		
APPROVED		

1. ALL DIMENSIONS ARE IN mm.
2. ROUND OFF ALL SHARP CORNERS WITH 0.40 mm.
3. TOLERANCES WILL BE AS PER BS:1474-1987 UNLESS OTHERWISE SPECIFIED

SCALE	4:1
AREA mm ²	79.86
PERIMETER mm.	141.322
WEIGHT kg/m	0.216

PARTY'S NAME SYDNEY ALUMINIUM & GLASS DOHA

PARTY'S DRAWING No. AS PER SAMPLE

ALLOY & TEMPER 6063 T6

DESCRIPTION GLAZING CLIP

DRAWING No.	SECTION No.
P-4694	-
4449	4449
19385	19385