

P-4880

44051

19393

MATCHING SECTION  
SCALE 1:1

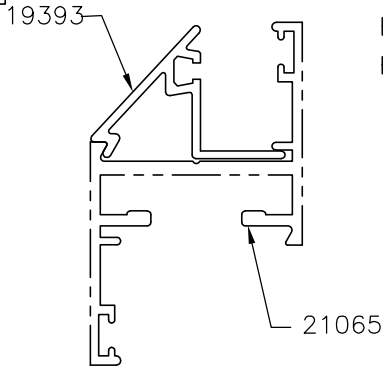

F = FULL RADIUS (3 PLACES)  
R = 0.50mm RADIUS (2 PLACES)

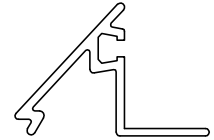

SCALE 1:1

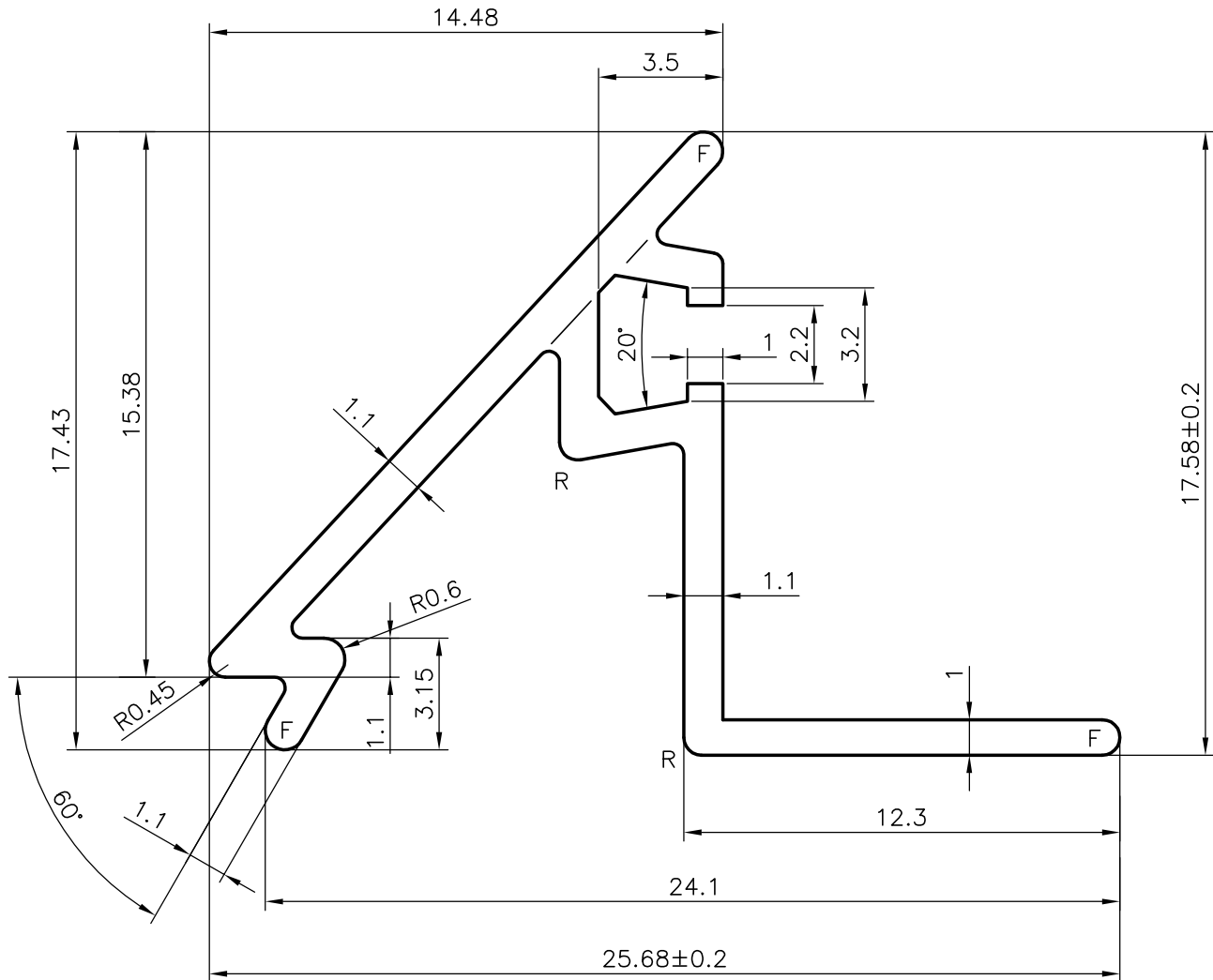

SYMBOL OF QUALITY  
AN ISO 9002 COMPANY

**JINDAL ALUMINIUM LTD.**  
BANGALORE-560073 (INDIA)

	NAME	DATE
DRAWN	RAGHAVENDRA	27-05-2004
CHECKED		
APPROVED		

1. ALL DIMENSIONS ARE IN mm.
2. ROUND OFF ALL SHARP CORNERS WITH 0.40 mm.
3. TOLERANCES WILL BE AS PER BS:1474-1987 UNLESS OTHERWISE SPECIFIED

SCALE	5:1
AREA mm <sup>2</sup>	60.871
PERIMETER mm.	108.426
WEIGHT kg/m	0.164

PARTY'S NAME	STAR GLASS ALUMINIUM C.C, SOUTH AFRICA
PARTY'S DRAWING No.	AF-2104
ALLOY & TEMPER	6063 T6
DESCRIPTION	GLAZING CLIP

DRAWING No.	SECTION No.
P-4880	-
44051	44051
19393	19393