

P-4302-2

S1032

19394

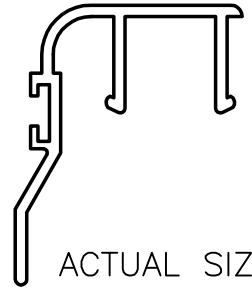

ACTUAL SIZE

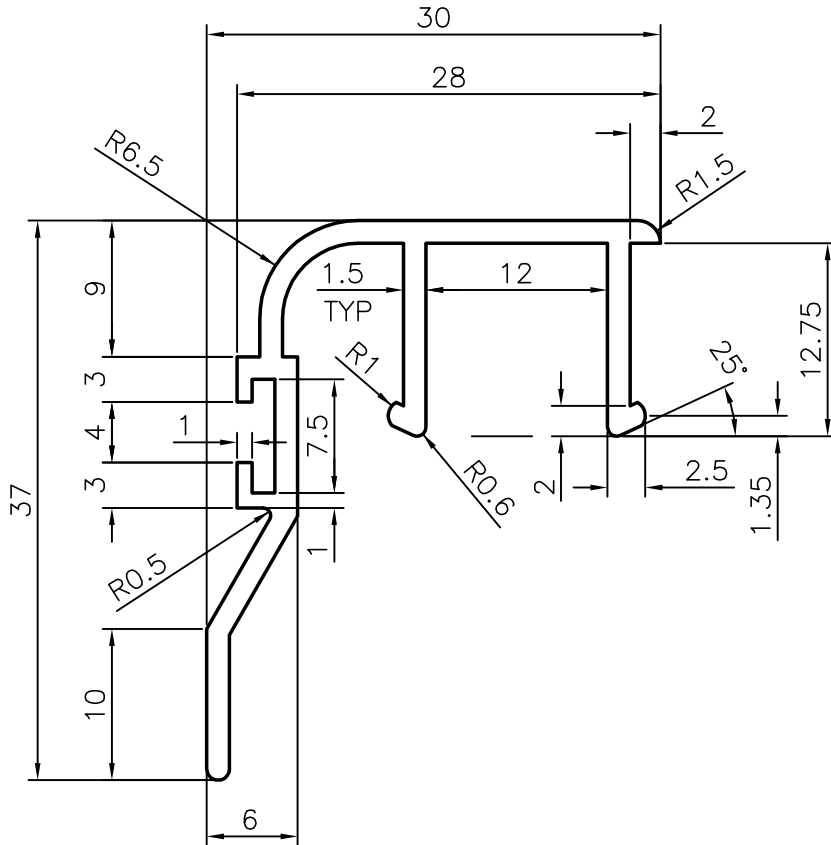

SYMBOL OF QUALITY
AN ISO 9002 COMPANY

JINDAL ALUMINIUM LTD.
BANGALORE-560073 (INDIA)

	NAME	DATE
DRAWN	MALINGAPPA	19.07.2003
CHECKED		
APPROVED		

1. ALL DIMENSIONS ARE IN mm.
2. ROUND OFF ALL SHARP CORNERS WITH 0.40 mm.
3. TOLERANCES WILL BE AS PER IS 3965-1981 UNLESS OTHERWISE SPECIFIED

SCALE	1:1/2:1
AREA mm ²	141
PERIMETER mm.	192.5
WEIGHT kg/m	0.380

PARTY'S NAME	ALUMINIUM GLASS & GLAZING
PARTY'S DRAWING No.	AS PER E-MAIL DRAWING
ALLOY & TEMPER	HE9 WP
DESCRIPTION	CLIP

DRAWING No.	SECTION No.
P-4302-2	-
S1032	S1032
19394	19394