

P-5514
19396

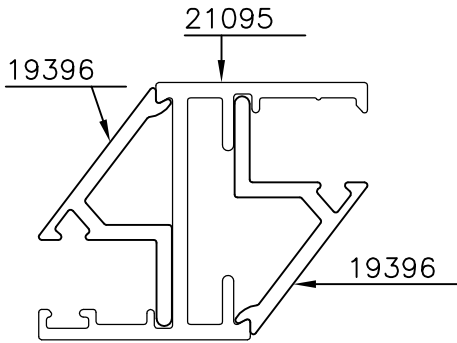

SCLALE-1:1

SCLALE-1:1

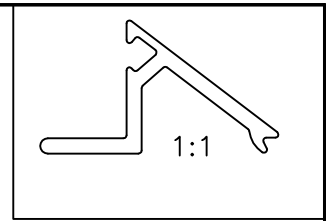
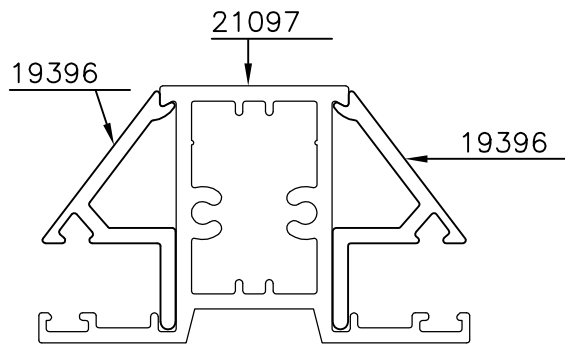
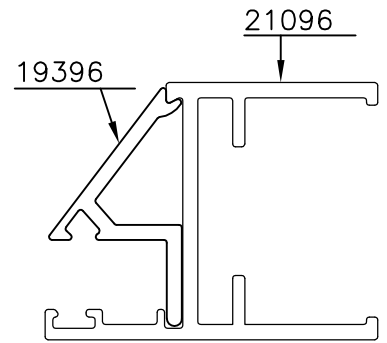

SCLALE-1:1

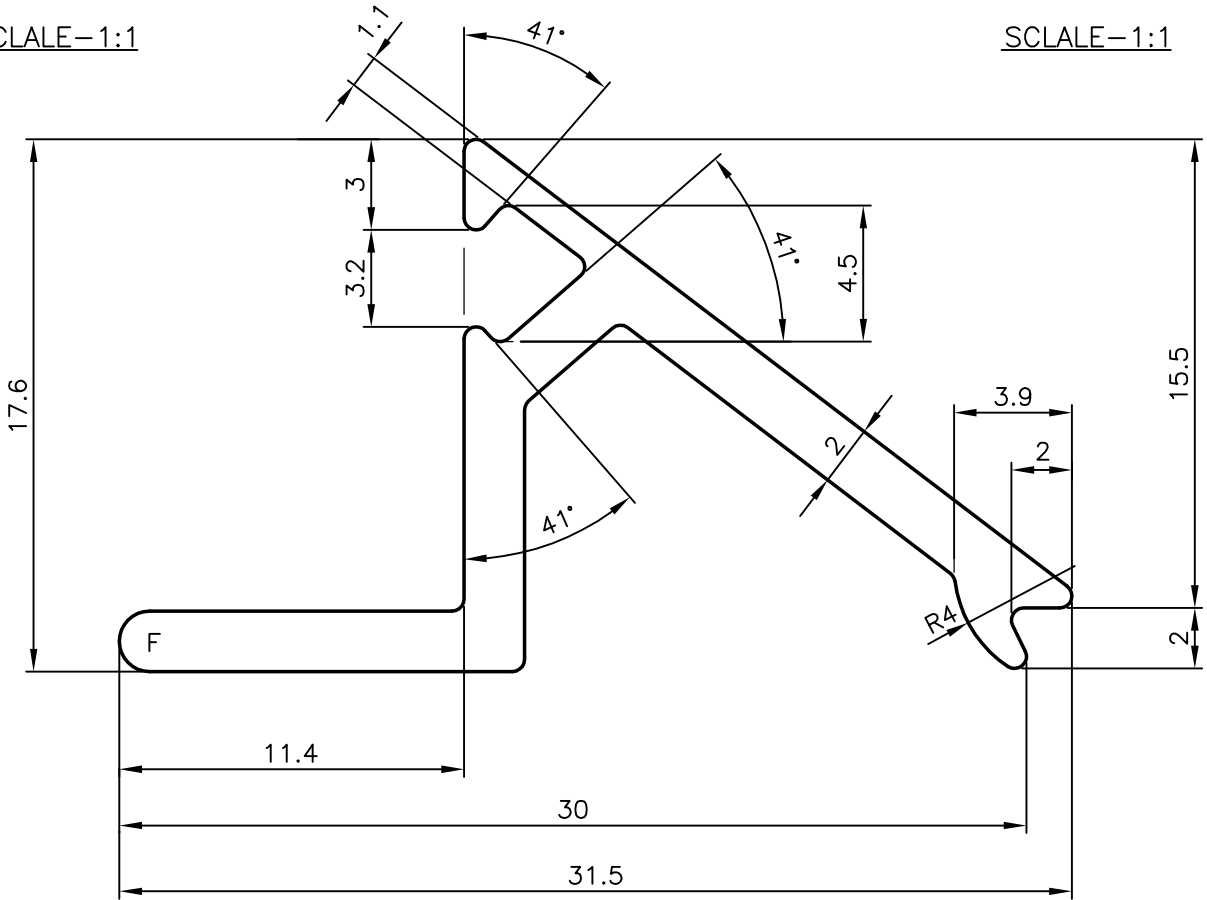

1. GENERAL WALL THICKNESS = 2mm
2. F = FULL RADIUS (1 PLACE)



SYMBOL OF QUALITY
AN ISO 9001 COMPANY

JINDAL ALUMINIUM LTD.
BANGALORE-560073 (INDIA)

	NAME	DATE
DRAWN	MALINGAPPA	25-05-2005
CHECKED		
APPROVED		
SCALE	4:1	
AREA mm ²	99.421	
PERIMETER mm.	108.005	
WEIGHT kg/m	0.268	
DRAWING No.	SECTION No.	
P-5514	-	
19396	19396	

1. ALL DIMENSIONS ARE IN mm.
2. ROUND OFF ALL SHARP CORNERS WITH 0.40 mm.
3. TOLERANCES WILL BE AS PER IS:3965-1981 UNLESS OTHERWISE SPECIFIED

PARTY'S NAME	GENERAL CATEGORY., KOLKATA MARKET
PARTY'S DRAWING No.	HEAVIER OF SECTION NO. 19375
ALLOY & TEMPER	HE9 WP
DESCRIPTION	GLAZING CLIP