

P-6775-1
19404

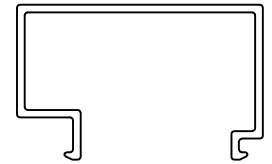

SCALE 1:1

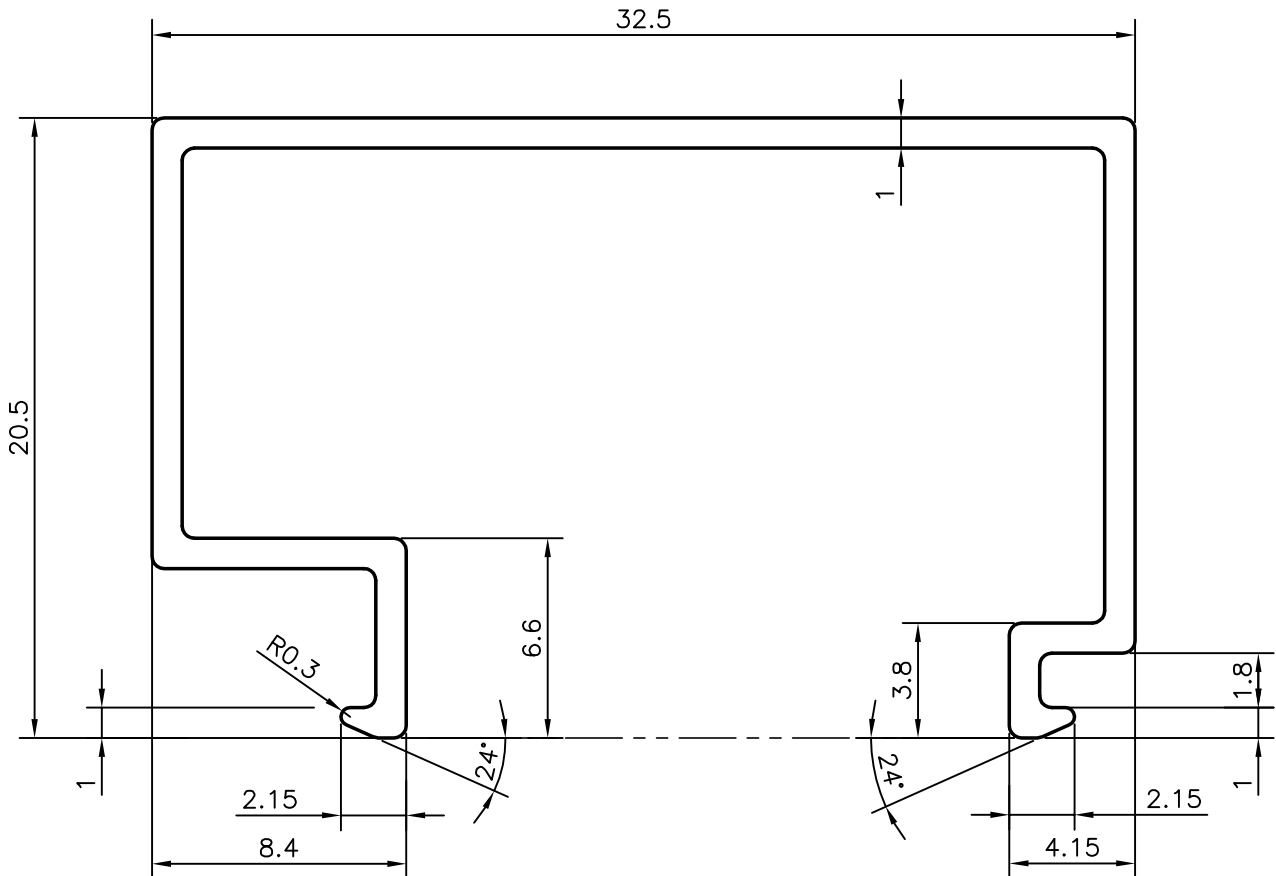

GENERAL WALL THICKNESS 1.0 mm

(EXCLUSIVE)

 SYMBOL OF QUALITY AN ISO 9001 COMPANY	JINDAL ALUMINIUM LTD. BANGALORE-560073 (INDIA)	DRAWN	NAME	DATE
		CHECKED	RAGHAVENDRA	02-11-2006
1. ALL DIMENSIONS ARE IN mm. 2. ROUND OFF ALL SHARP CORNERS WITH 0.40 mm. 3. TOLERANCES WILL BE AS PER IS:3965-1981 UNLESS OTHERWISE SPECIFIED		APPROVED		
		SCALE		4:1
PARTY'S NAME GWS FABRICATORS PVT. LTD., MUMBAI		AREA mm ²		83.724
		PERIMETER mm.		166.807
PARTY'S DRAWING No. GWS-ST.GLAZING-DIE-05		WEIGHT kg/m		0.226
		DRAWING No.	SECTION No.	
ALLOY & TEMPER 6063 T6		P-6775-1		-
		19404		19404
DESCRIPTION SP. CLIP SECTION				