

P-6849-1

19406

MATCHING SECTION

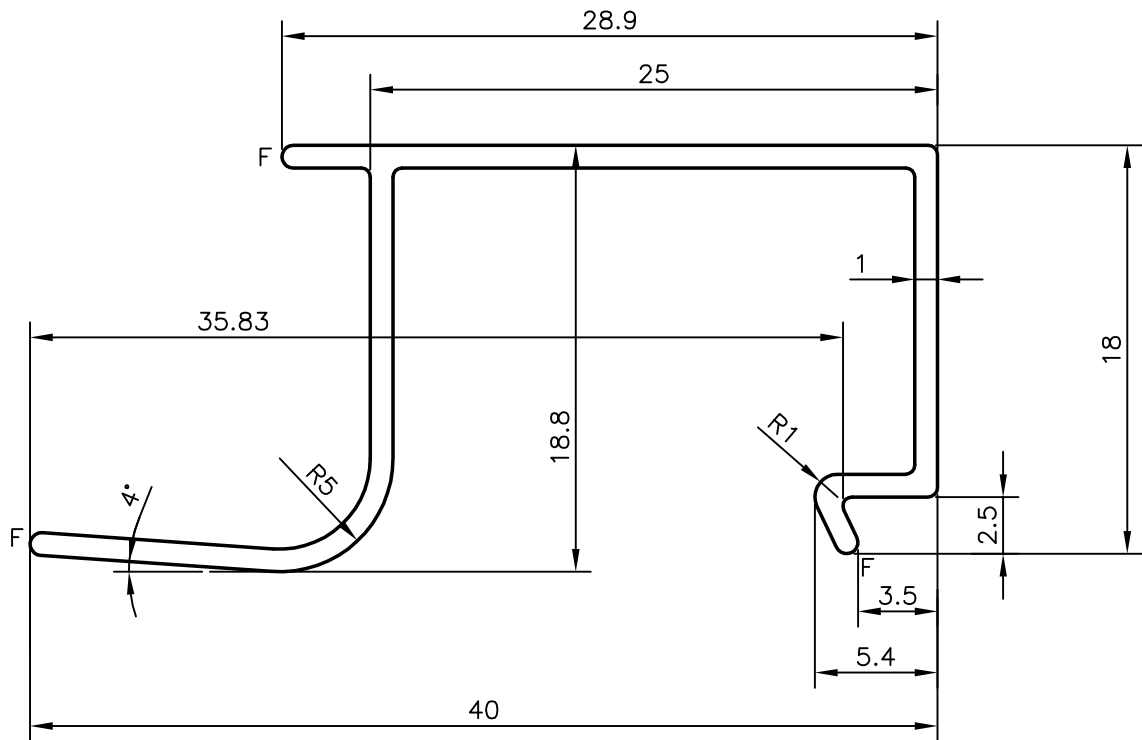
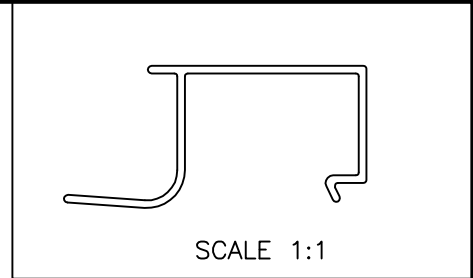
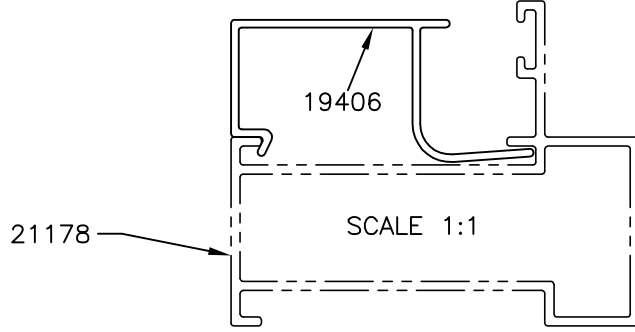

F = FULL RADIUS (3 PLACES)  
 GENERAL WALL THICKNESS = 1.00mm



SYMBOL OF QUALITY  
 AN ISO 9001 COMPANY

**JINDAL ALUMINIUM LTD.**  
 BANGALORE-560073 (INDIA)

	NAME	DATE
DRAWN	RAGHAVENDRA	30-11-2006
CHECKED		
APPROVED		

1. ALL DIMENSIONS ARE IN mm.
2. ROUND OFF ALL SHARP CORNERS WITH 0.40 mm.
3. TOLERANCES WILL BE AS PER EN12020-2:2001 UNLESS OTHERWISE SPECIFIED

SCALE	3:1
AREA mm <sup>2</sup>	81.018
PERIMETER mm.	161.579
WEIGHT kg/m	0.219

PARTY'S NAME	PRAYOSH ENTERPRISES, UGANDA
PARTY'S DRAWING No.	AS PER SAMPLE & AS PER REQUIREMENT
ALLOY & TEMPER	6063 T6
DESCRIPTION	GLAZING CLIP SECTION

DRAWING No.	SECTION No.
P-6849-1	-
19406	19406