

P-8902-1

19422

MATCHING SECTION

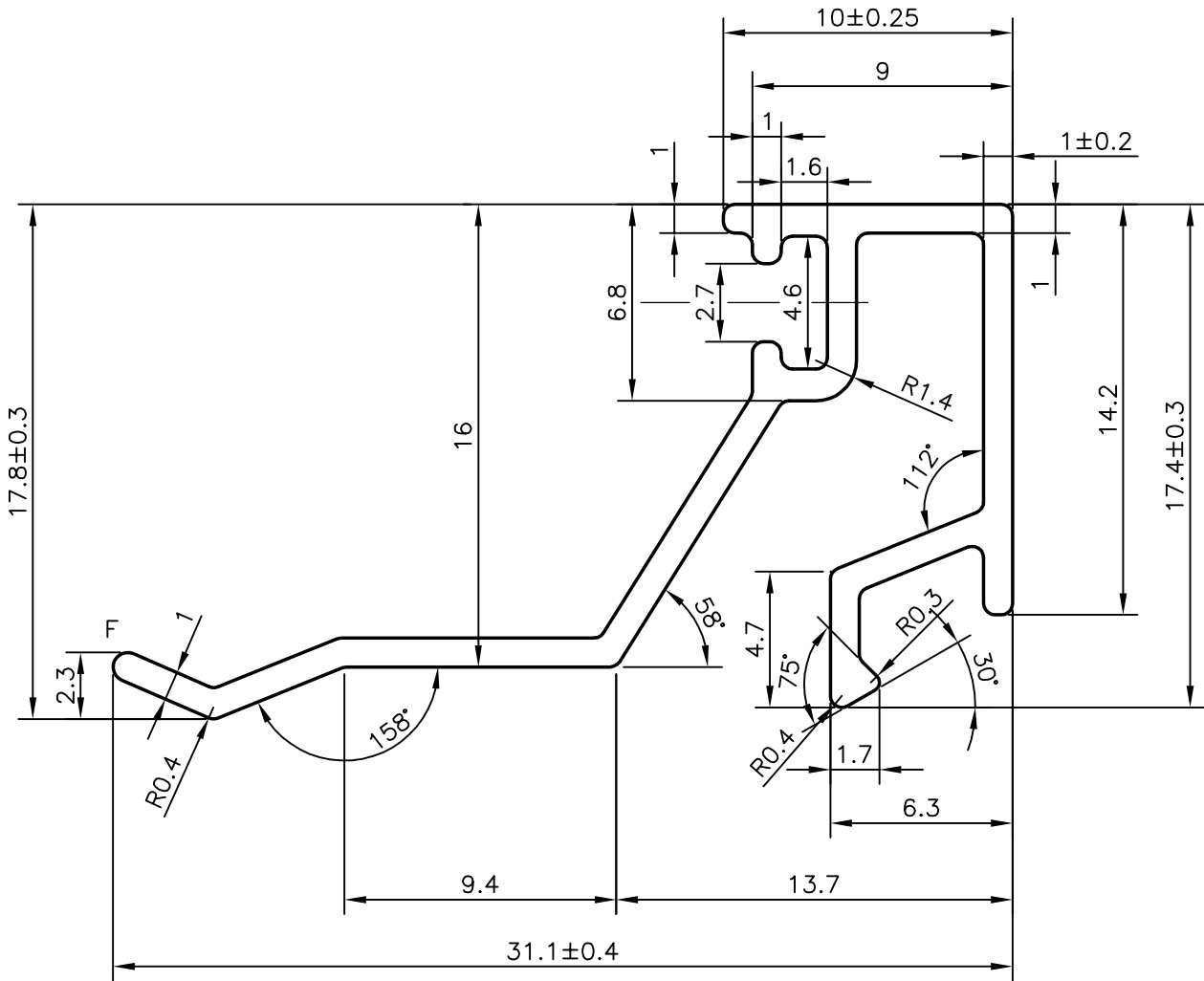
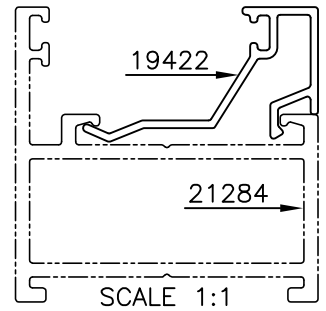

F = FULL RADIUS (1 PLACE)
 UNSPECIFIED WALL THICKNESS = 1.00 mm



SYMBOL OF QUALITY
 AN ISO 9001 COMPANY

JINDAL ALUMINIUM LTD.
 BANGALORE-560073 (INDIA)

	NAME	DATE
DRAWN	PRASANNA.H	06-01-2009
CHECKED		
APPROVED		
SCALE	4:1	
AREA mm ²	71.564	
PERIMETER mm.	139.697	
WEIGHT kg/m	0.193	
DRAWING No.	SECTION No.	
P-8902-1	-	
19422	19422	

1. ALL DIMENSIONS ARE IN mm.
2. ROUND OFF ALL SHARP CORNERS WITH 0.40 mm.
3. TOLERANCES WILL BE AS PER IS:3965-1981 UNLESS OTHERWISE SPECIFIED

PARTY'S NAME	GENERAL CATEGORY., AHMEDABAD MARKET
PARTY'S DRAWING No.	AS PER DRAWING
ALLOY & TEMPER	HE9 WP
DESCRIPTION	GLAZING CLIP