

P-9918

19428

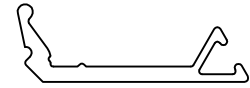

SCALE 1:1

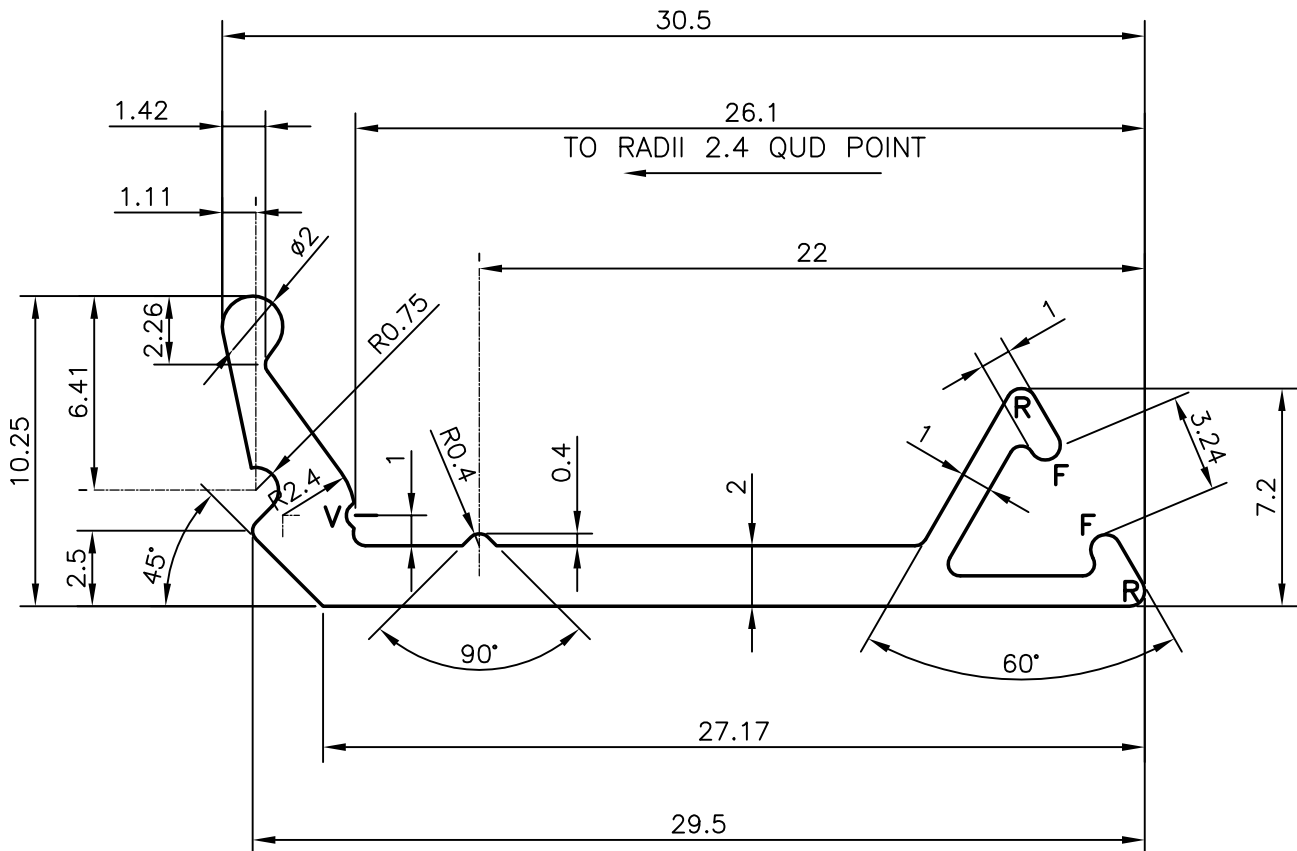

R = RADII 0.50 (2-PLACE)
 F = RADII FULL (2-PLACE)
 V = GROOVE 0.30x90° (1-PLACE) INCLUDING R0.30



SYMBOL OF QUALITY
 AN ISO 9001 COMPANY

JINDAL ALUMINIUM LTD.
 BANGALORE-560073 (INDIA)

	NAME	DATE
DRAWN	RAGHAVENDRA	23-03-2010
CHECKED		
APPROVED	S.S.GARG	27-03-2010

1. ALL DIMENSIONS ARE IN mm.
2. ROUND OFF ALL SHARP CORNERS WITH 0.40 mm.
3. TOLERANCES WILL BE AS PER IS:3965-1981 UNLESS OTHERWISE SPECIFIED

SCALE	4:1
AREA mm ²	76.424
PERIMETER mm.	93.14
WEIGHT kg/m	0.206

PARTY'S NAME	GENERAL CATEGORY, DELHI MARKET
PARTY'S DRAWING No.	AS PER REQUIREMENT (19378)
ALLOY & TEMPER	6063 T6
DESCRIPTION/END USE	GLAZING CLIP

DRAWING No.	SECTION No.
P-9918	-
19428	19428