

P-10283

19430

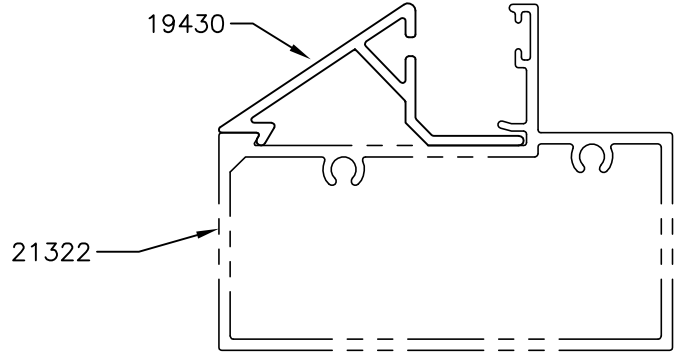

F = FULL RADIUS (2 PLACES)

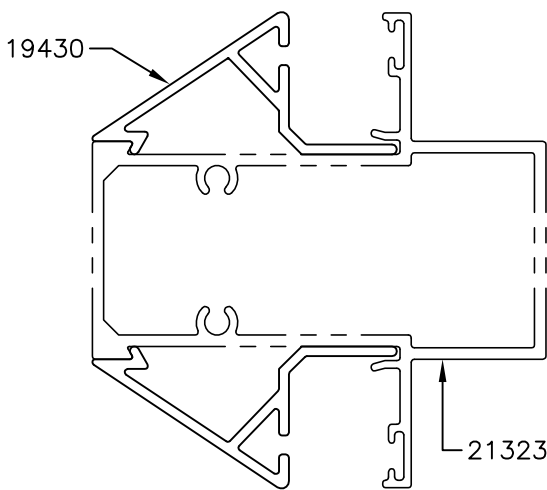
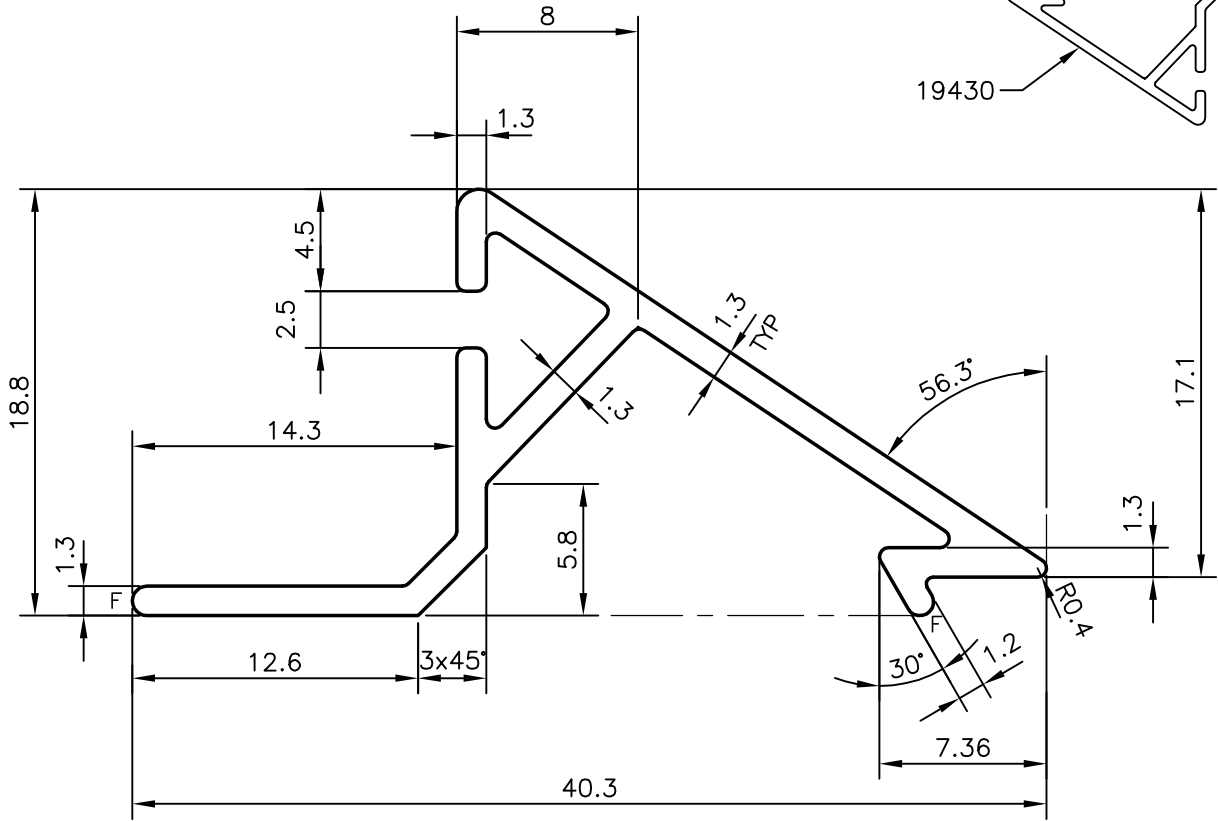
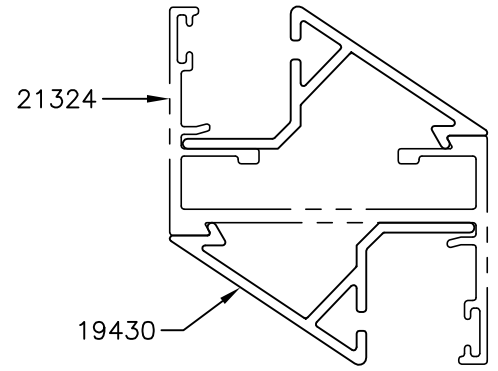

SYMBOL OF QUALITY  
AN ISO 9001 COMPANY

**JINDAL ALUMINIUM LTD.**  
BANGALORE-560073 (INDIA)

	NAME	DATE
DRAWN	J.P.KAUSHIK	09-08-2010
CHECKED		
APPROVED	S.S.GARG	09-10-2010
SCALE		3:1
AREA mm <sup>2</sup>		95.788
PERIMETER mm.		141.412
WEIGHT kg/m		0.259
DRAWING No.	SECTION No.	
P-10283	-	
19430	19430	

1. ALL DIMENSIONS ARE IN mm.
2. ROUND OFF ALL SHARP CORNERS WITH 0.40 mm.
3. TOLERANCES WILL BE AS PER BS:EN-755 UNLESS OTHERWISE SPECIFIED

PARTY'S NAME	PRAYOSHA ENTERPRISES LTD., UGANDA
PARTY'S DRAWING No.	AS PER SAMPLE
ALLOY & TEMPER	6063 T6
DESCRIPTION	GLAZING CLIP