

P-11693

S3336

19447

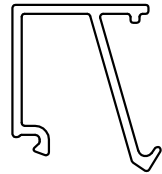

SCALE:- 1:1

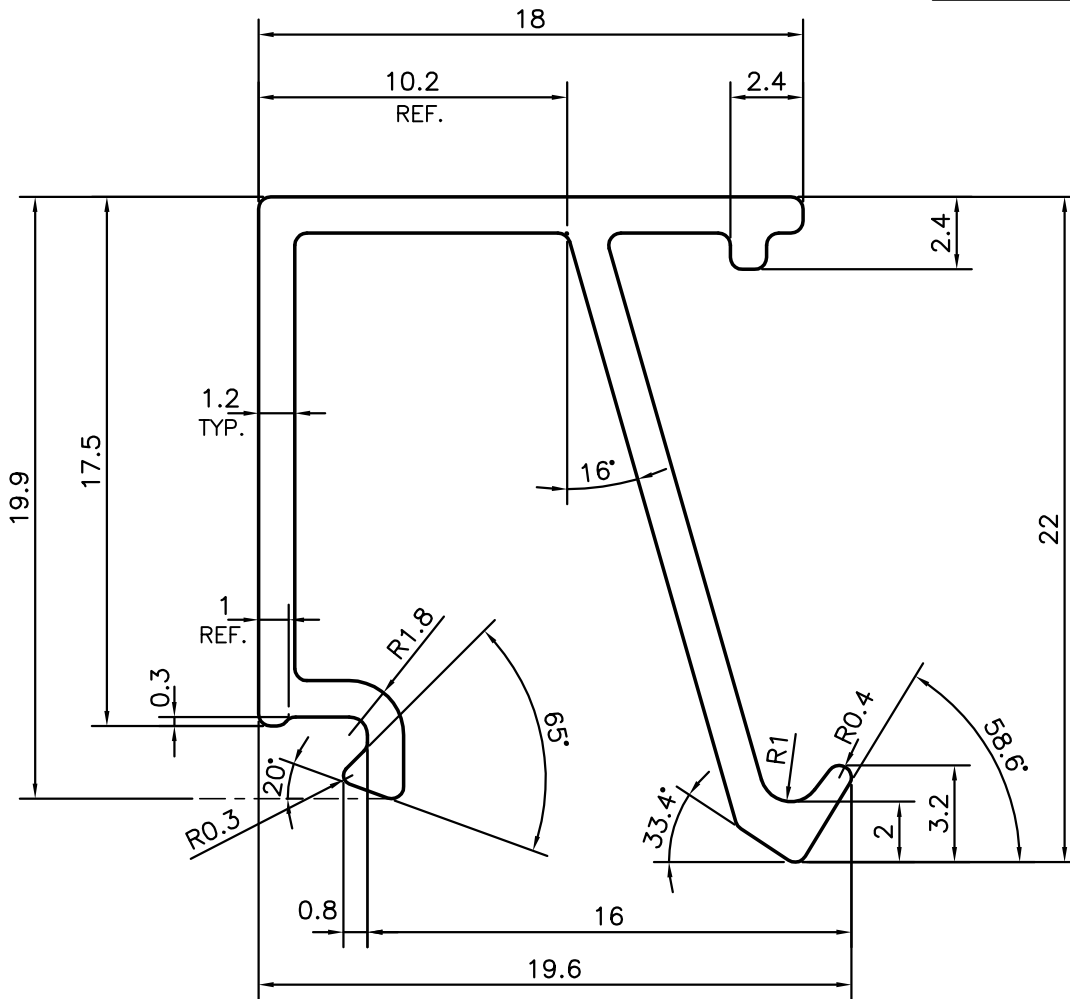

Q71740



SYMBOL OF QUALITY
AN ISO 9001 COMPANY

JINDAL ALUMINIUM LTD.
BANGALORE-560073 (INDIA)

| | NAME | DATE |
|----------------------|-------------|------------|
| DRAWN | PARVESH | 23-04-2012 |
| CHECKED | | |
| APPROVED | S.S.GARG | 06-06-2012 |
| SCALE | | 4:1 |
| AREA mm ² | | 79.245 |
| PERIMETER mm. | | 130.726 |
| WEIGHT kg/m | | 0.214 |
| DRAWING No. | SECTION No. | |
| P-11693 | - | |
| S3336 | S3336 | |
| 19447 | 19447 | |

1. ALL DIMENSIONS ARE IN mm.
2. ROUND OFF ALL SHARP CORNERS WITH 0.40 mm.
3. TOLERANCES WILL BE AS PER IS:3965-1981 , UNLESS OTHERWISE SPECIFIED

| | |
|---------------------|---------------------------------|
| PARTY'S NAME | SAHARA PRIME CITY LTD., GURGAON |
| PARTY'S DRAWING No. | F3 |
| ALLOY & TEMPER | HE9 WP |
| DESCRIPTION | GLAZING CLIP SECTION |