

P-12328-1

S3601

19462

EXPOSED  
SURFACE

SCALE :- 1:1

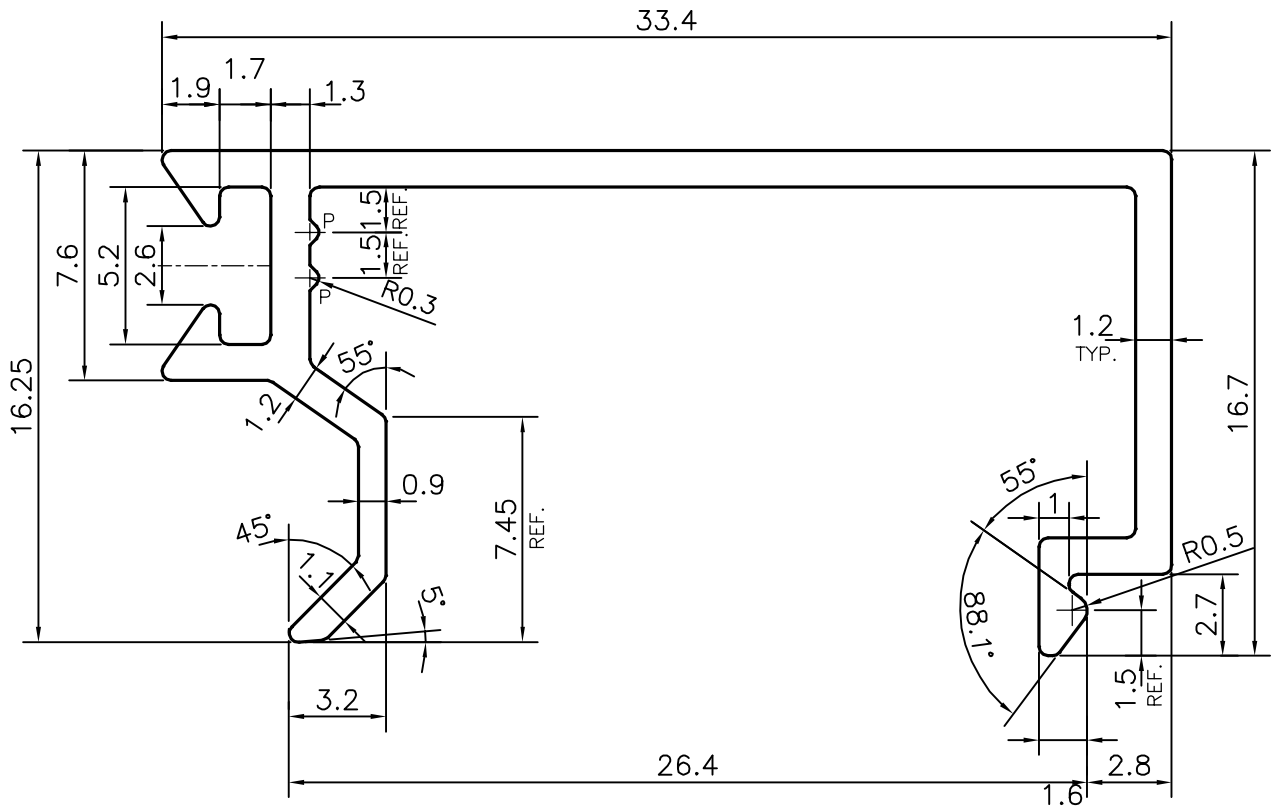

P = PIP 0.3x90° (2 PLACES)



SYMBOL OF QUALITY  
AN ISO 9001 COMPANY

**JINDAL ALUMINIUM LTD.**  
BANGALORE-560073 (INDIA)

	NAME	DATE
DRAWN	PARVESH	26-12-2012
CHECKED		
APPROVED	S.S.GARG	10-01-2013
SCALE		4:1
AREA mm <sup>2</sup>		88.697
PERIMETER mm.		149.744
WEIGHT kg/m		0.239
DRAWING No.	SECTION No.	
P-12328-1	-	
S3601	S3601	
19462	19462	

1. ALL DIMENSIONS ARE IN mm.
2. ROUND OFF ALL SHARP CORNERS WITH 0.30 mm.
3. TOLERANCES WILL BE AS PER IS:3965-1981 , UNLESS OTHERWISE SPECIFIED

PARTY'S NAME	RBS IMPEX, LUDHIANA
PARTY'S DRAWING No.	VB11549
ALLOY & TEMPER	6060 T6
DESCRIPTION	GLAZING CLIP SECTION