

P-12491

S3637

19464

EXPOSED SURFACE

SCALE: - 1:1

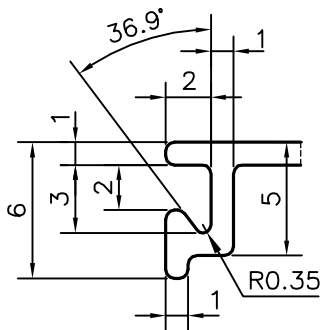
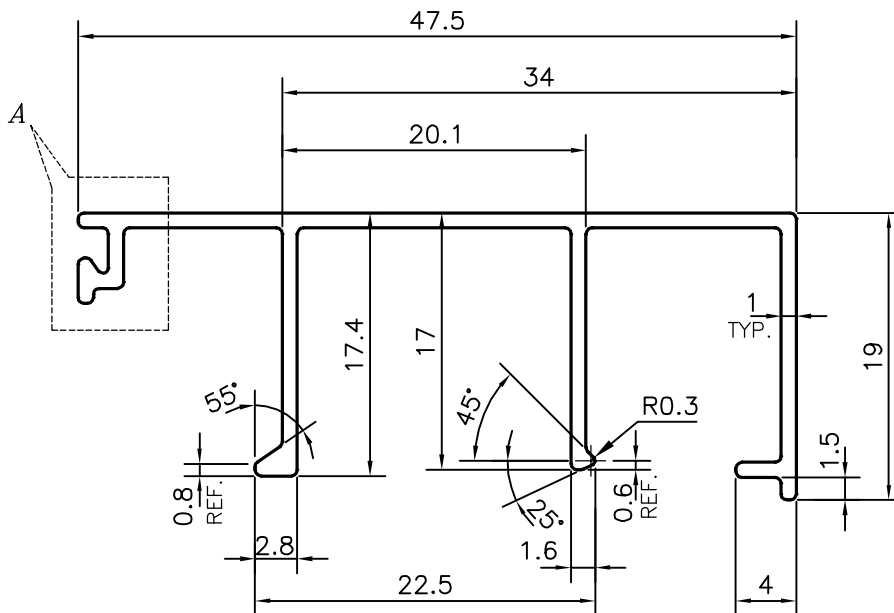

DETAIL OF "A"
SCALE 3:1

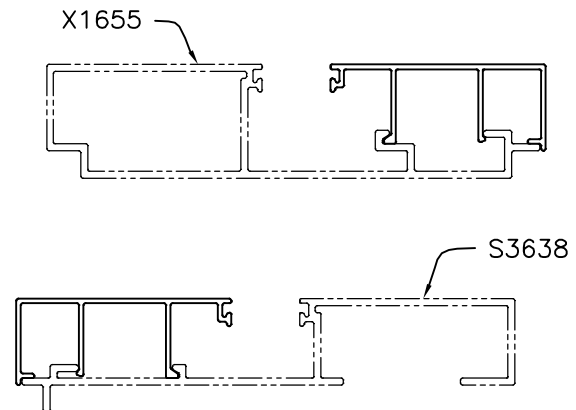

SYMBOL OF QUALITY
AN ISO 9001 COMPANY

JINDAL ALUMINIUM LTD.
BANGALORE-560073 (INDIA)

	NAME	DATE
DRAWN	PARVESH	31-01-2013
CHECKED		
APPROVED	S.S.GARG	07-02-2013
SCALE		2:1
AREA mm ²		111.892
PERIMETER mm.		218.102
WEIGHT kg/m		0.302
DRAWING No.	SECTION No.	
P-12491	-	
S3637	S3637	
19464	19464	

1. ALL DIMENSIONS ARE IN mm.
2. ROUND OFF ALL SHARP CORNERS WITH 0.40 mm.
3. TOLERANCES WILL BE AS PER IS:3965-1981 , UNLESS OTHERWISE SPECIFIED

PARTY'S NAME	SOUNDARYA DECORATORS PVT. LTD., CHENNAI
PARTY'S DRAWING No.	AS PER Auto CAD DRAWING-110-C1
ALLOY & TEMPER	HE9 WP
DESCRIPTION	DOOR PARTITION SECTION-CLIP