

P-10907-2

S2969

19470

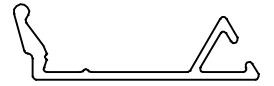

1:1

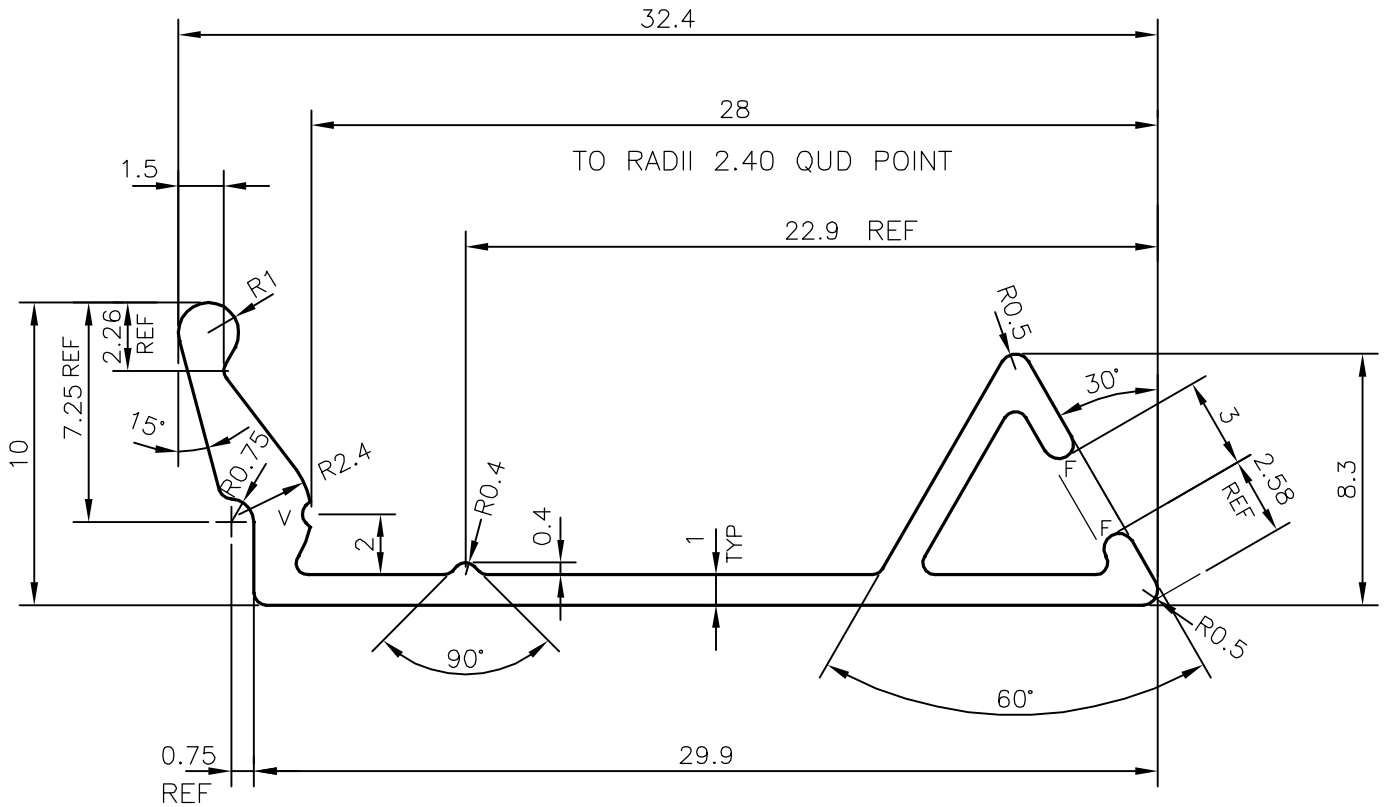

V = V GROOVE 0.3x90°
 F= FULL RADIUS (2 PLACES)



SYMBOL OF QUALITY
 AN ISO 9001 COMPANY

JINDAL ALUMINIUM LTD.
 BANGALORE-560073 (INDIA)

	NAME	DATE
DRAWN	J.P.KAUSHIK	10-05-2011
CHECKED		
APPROVED	S.S.GARG	09-06-2011
SCALE		4:1
AREA mm ²		62
PERIMETER mm.		103.102
WEIGHT kg/m		0.168
DRAWING No.	SECTION No.	
P-10907-2	-	
S2969	S2969	
19470	19470	

1. ALL DIMENSIONS ARE IN mm.
2. ROUND OFF ALL SHARP CORNERS WITH 0.40 mm.
3. TOLERANCES WILL BE AS PER IS:3965-1981 UNLESS OTHERWISE SPECIFIED

PARTY'S NAME: DG-MAP, NEW DELHI

PARTY'S DRAWING No.: DGM-17

ALLOY & TEMPER: HE9 WP

DESCRIPTION: BEADING SECTION