

P-15590

19474

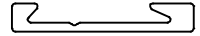

1:1

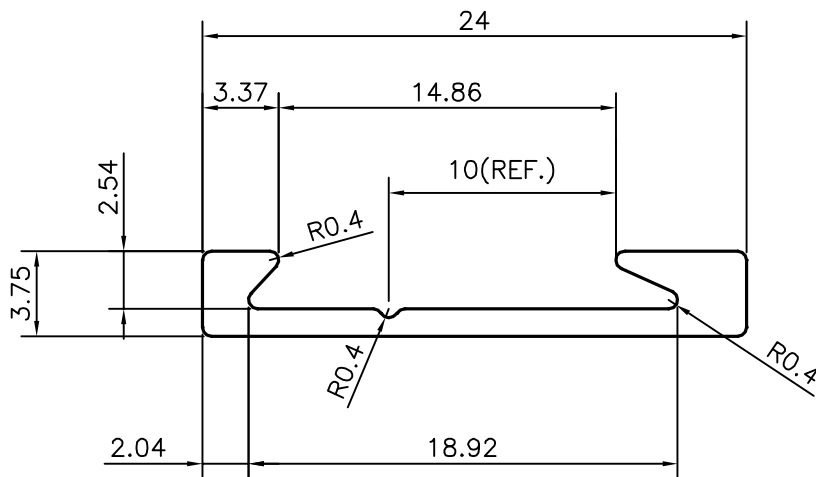

SYMBOL OF QUALITY
AN ISO 9001 COMPANY

JINDAL ALUMINIUM LTD.
BANGALORE-560073 (INDIA)

	NAME	DATE
DRAWN	J.P.KAUSHIK	08-02-2016
CHECKED		
APPROVED	S.S. GARG	18-05-2016

1. ALL DIMENSIONS ARE IN mm.
2. ROUND OFF ALL SHARP CORNERS WITH 0.40 mm.
3. TOLERANCES WILL BE AS PER,BS:EN-755-9 UNLESS OTHERWISE SPECIFIED

SCALE	3:1
AREA mm ²	46.685
PERIMETER mm.	65.703
WEIGHT kg/m	0.126

PARTY'S NAME	PRAYOSHA ENTERPRISES LTD., UGANDA	DRAWING No.	P-15590	SECTION No.	-
PARTY'S DRAWING No.	AS PER DRAWING		19474		19474
ALLOY & TEMPER	6063 T6				
DESCRIPTION	GLAZING PLATE				