

P-15382

S4753

19497

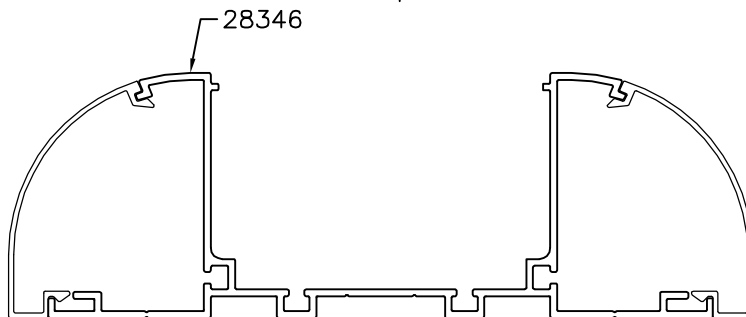
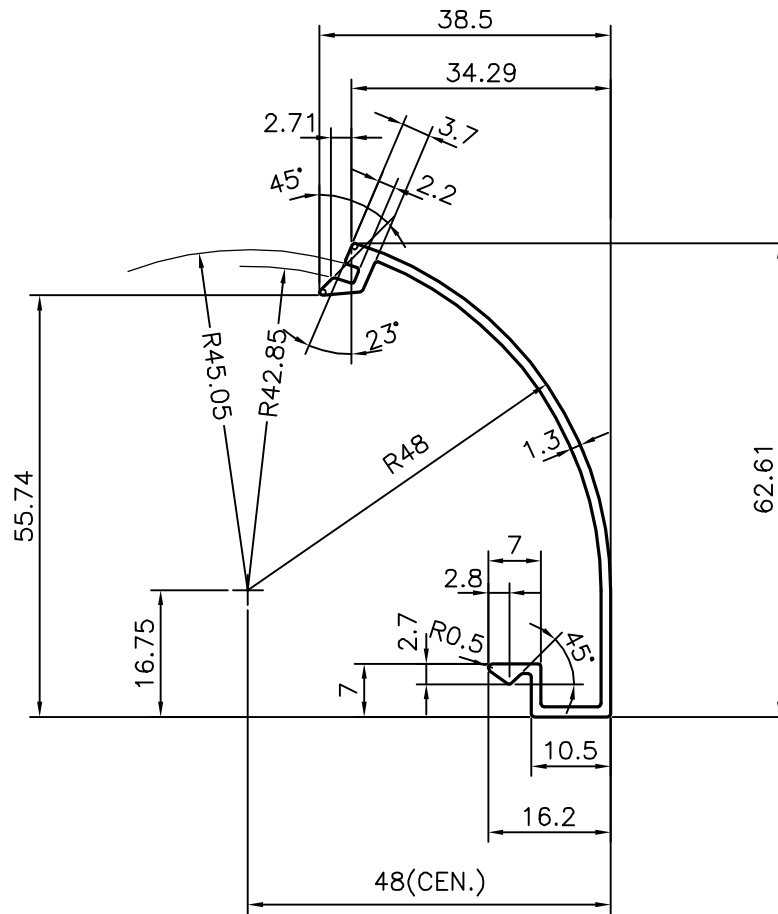

SYMBOL OF QUALITY
AN ISO 9001 COMPANY

JINDAL ALUMINIUM LTD.
BANGALORE-560073 (INDIA)

	NAME	DATE
DRAWN	J.P.KAUSHIK	01-12-2015
CHECKED		
APPROVED	S.S.GARG	05-12-2015
SCALE		1:1
AREA mm ²		147.4
PERIMETER mm.		214.986
WEIGHT kg/m		0.398
DRAWING No.		SECTION No.
P-15382		-
S4753		S4753
19497		19497

1. ALL DIMENSIONS ARE IN mm.
2. ROUND OFF ALL SHARP CORNERS WITH 0.4 mm.
3. TOLERANCES WILL BE AS PER IS:3965-1981, UNLESS OTHERWISE SPECIFIED

PARTY'S NAME	KARNATAKA INDUSTRIES, BANGALORE
PARTY'S DRAWING No.	AS PER SAMPLE & REQUIREMENT
ALLOY & TEMPER	HE9 WP
DESCRIPTION	CLIP SECTION