

4504

10503

19501

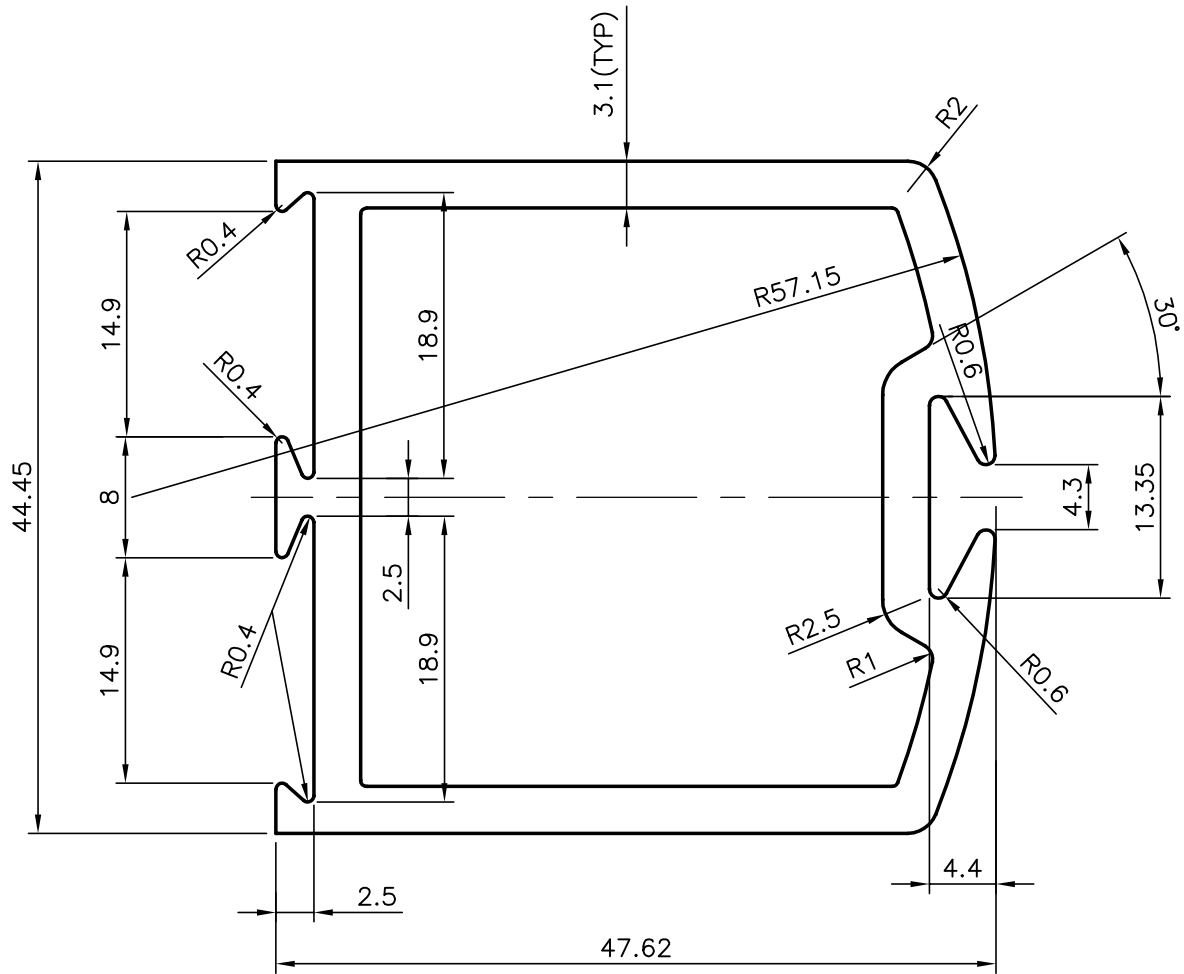
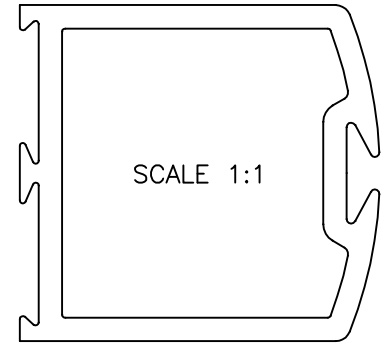

GENERAL WALL THICKNESS = 3.10mm



SYMBOL OF QUALITY
AN ISO 9001 COMPANY

JINDAL ALUMINIUM LTD.
BANGALORE-560073 (INDIA)

	NAME	DATE
DRAWN	RAGHAVENDRA	02-02-2005
CHECKED		
APPROVED		
SCALE		2:1
AREA mm ²		558.75
PERIMETER mm.		218.451
WEIGHT kg/m		1.509
DRAWING No.	SECTION No.	
4504	-	
10503	10503	
19501	19501	

1. ALL DIMENSIONS ARE IN mm.
2. ROUND OFF ALL SHARP CORNERS WITH 0.40 mm.
3. TOLERANCES WILL BE AS PER IS:6477-1983 UNLESS OTHERWISE SPECIFIED

PARTY'S NAME	-
PARTY'S DRAWING No.	-
ALLOY & TEMPER	HE9 WP
DESCRIPTION	DOOR SECTION