

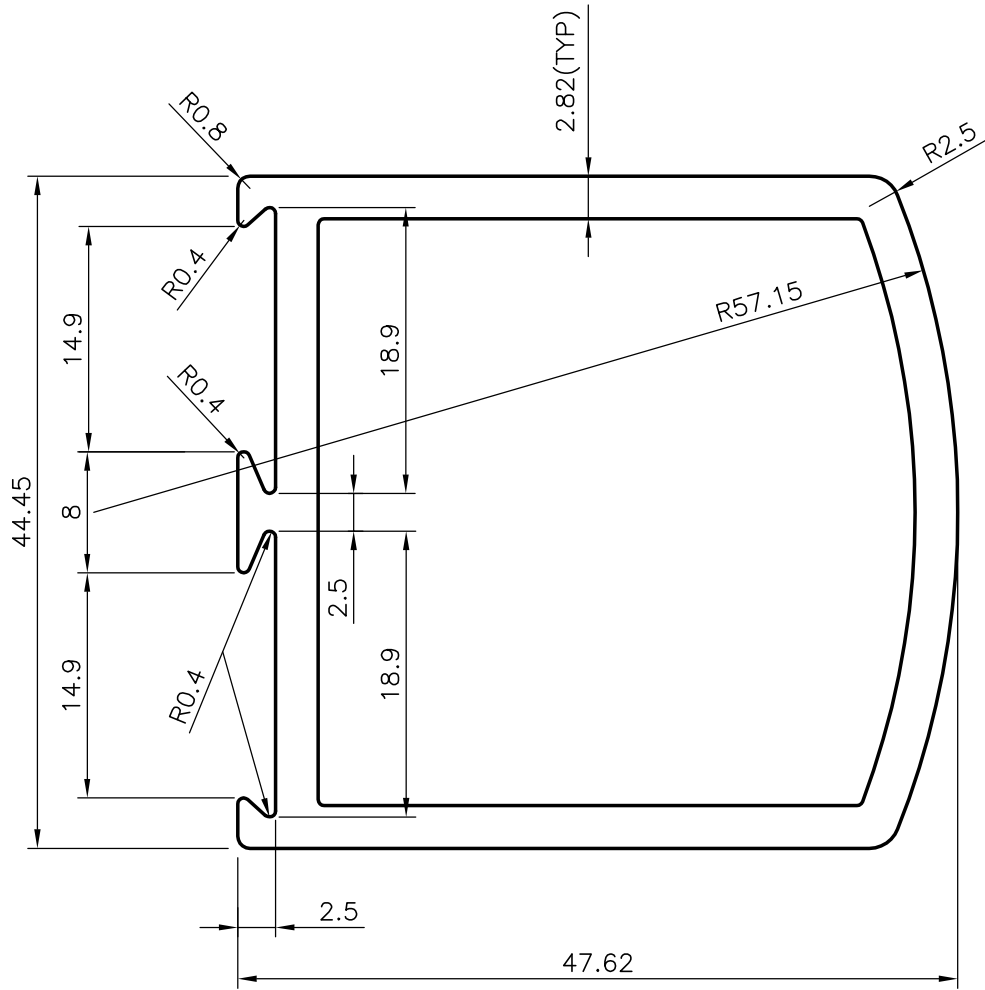

4505
10522
19502

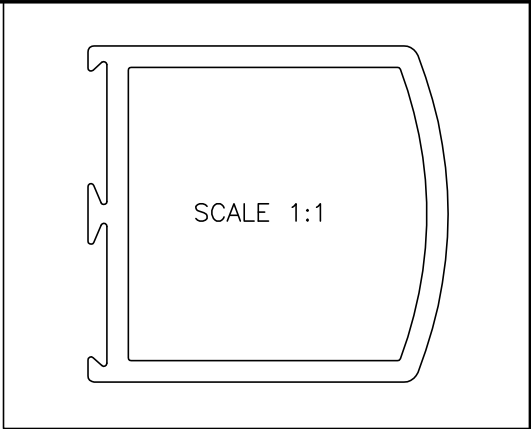

GENERAL WALL THICKNESS = 2.82mm

 SYMBOL OF QUALITY AN ISO 9001 COMPANY	JINDAL ALUMINIUM LTD. BANGALORE-560073 (INDIA)	NAME		DATE
		DRAWN	RAGHAVENDRA	02-02-2005
1. ALL DIMENSIONS ARE IN mm. 2. ROUND OFF ALL SHARP CORNERS WITH 0.40 mm. 3. TOLERANCES WILL BE AS PER IS:6477-1983 UNLESS OTHERWISE SPECIFIED		CHECKED		
		APPROVED		
PARTY'S NAME -		SCALE		2:1
		AREA mm ²		479.325
PARTY'S DRAWING No. -		PERIMETER mm.		195.936
		WEIGHT kg/m		1.294
ALLOY & TEMPER HE9 WP		DRAWING No.		4505
		SECTION No.		-
DESCRIPTION DOOR SECTION		10522		10522
		19502		19502