

| |
|-------|
| 4526 |
| 10551 |
| 19509 |

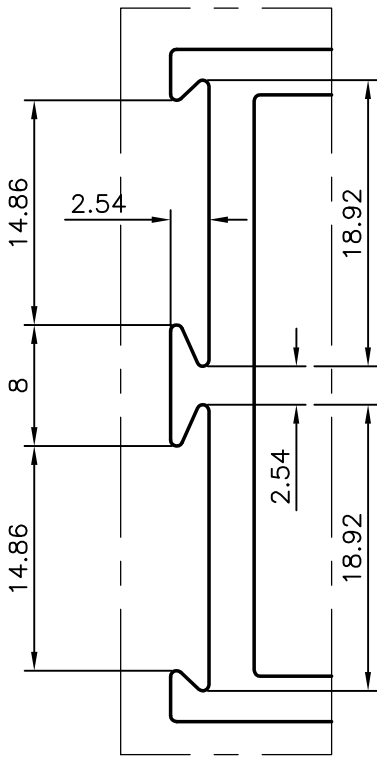

DETAIL-A
SCALE: -2:1

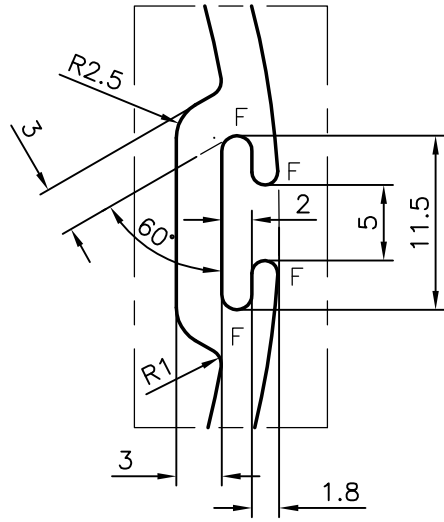

DETAIL-B
SCALE: -2:1

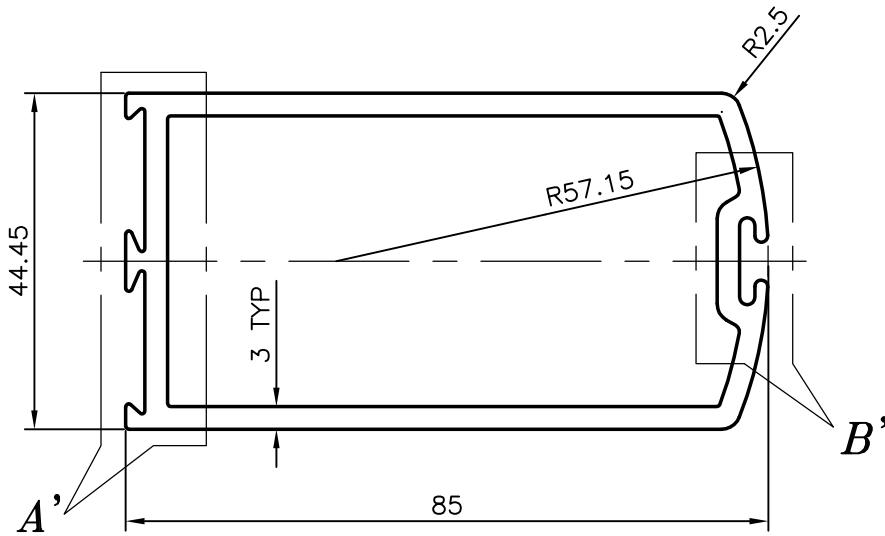

GENERAL WALL THICKNESS = 3 mm.
F = FULL RADIUS (4 PLACES)

| | | | |
|------------------------------------------------------------------------------------------------------------------------------------------------------|----------------------------------------------------------|----------------------|-----------------------|
|  SYMBOL OF QUALITY AN ISO 9001 COMPANY | JINDAL ALUMINIUM LTD. BANGALORE-560073 (INDIA) | NAME | DATE |
| | | DRAWN | MALINGAPPA 28-09-2005 |
| | | CHECKED | |
| 1. ALL DIMENSIONS ARE IN mm. 2. ROUND OFF ALL SHARP CORNERS WITH 0.50 mm. 3. TOLERANCES WILL BE AS PER IS:6477-1983 UNLESS OTHERWISE SPECIFIED | | APPROVED | |
| PARTY'S NAME | - | SCALE | 1:1 |
| PARTY'S DRAWING No. | - | AREA mm ² | 755.818 |
| ALLOY & TEMPER | HE9 WP | PERIMETER mm. | 288.374 |
| DESCRIPTION | DOOR SECTION | WEIGHT kg/m | 2.050 |
| | | DRAWING No. | SECTION No. |
| | | 4526 | 4526 |
| | | 10551 | 10551 |
| | | 19509 | 19509 |