

4537

10501

19516

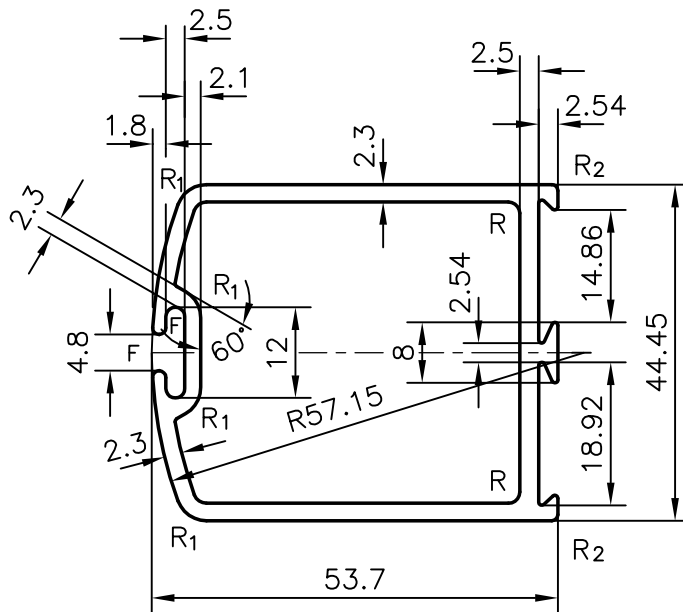

1. R = 1.5 RADIUS (2)
2. R<sub>1</sub> = 4.0 RADIUS (4)
3. R<sub>2</sub> = 0.8 RADIUS (2)

**JINDAL ALUMINIUM LTD.**  
**BANGALORE-560073**

NAME

DATE

DRAWN

R.D.Sharma

1-7-95

CHECKED

APPROVED

1. ALL DIMENSIONS ARE IN mm.
2. ROUND OFF ALL SHARP CORNERS WITH 0.4 mm.
3. TOLERANCES WILL BE AS PER IS : 6477-1983  
UNLESS OTHERWISE SPECIFIED

PARTY'S NAME

-

SCALE

1:1

PARTY'S DRAWING No.

-

WEIGHT kg/m

1.238

ALLOY &amp; TEMPER

HE9 WP

SECTION No.

19516

LENGTH

3658 mm.

DRAWING No.

DESCRIPTION

DOOR SECTION

19516