

4540

10521

19518

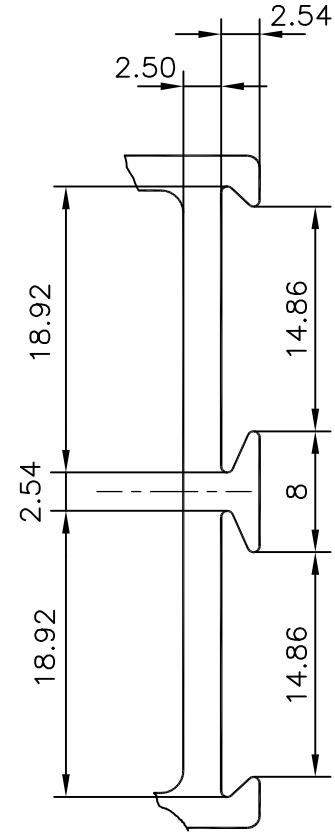
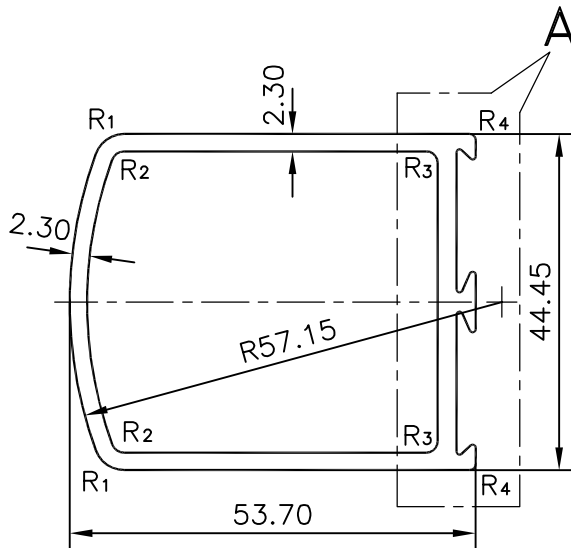

DETAIL AT "A"

- $R_1 = \text{RADIUS } 4 \text{ (2)}$   
 $R_2 = \text{RADIUS } 1.70 \text{ (2)}$   
 $R_3 = \text{RADIUS } 1.50 \text{ (2)}$   
 $R_4 = \text{RADIUS } 0.80 \text{ (2)}$

**JINDAL ALUMINIUM LTD.**  
**BANGALORE-560073**

NAME

DATE

DRAWN

R.D.Sharma

9-10-95

CHECKED

APPROVED

1. ALL DIMENSIONS ARE IN mm.  
 2. ROUND OFF ALL SHARP CORNERS WITH 0.4 mm.  
 3. TOLERANCES WILL BE AS PER IS : 6477-1983  
 UNLESS OTHERWISE SPECIFIED

PARTY'S NAME

METAL BRITES, MADRAS

SCALE

1:1 &amp; 2:1

PARTY'S DRAWING No.

-

WEIGHT kg/m

1.173

ALLOY &amp; TEMPER

HE9 WP

SECTION No.

19518

LENGTH

4570 mm.

DRAWING No.

DESCRIPTION

DOOR SECTION

19518