

4542

10632

19520

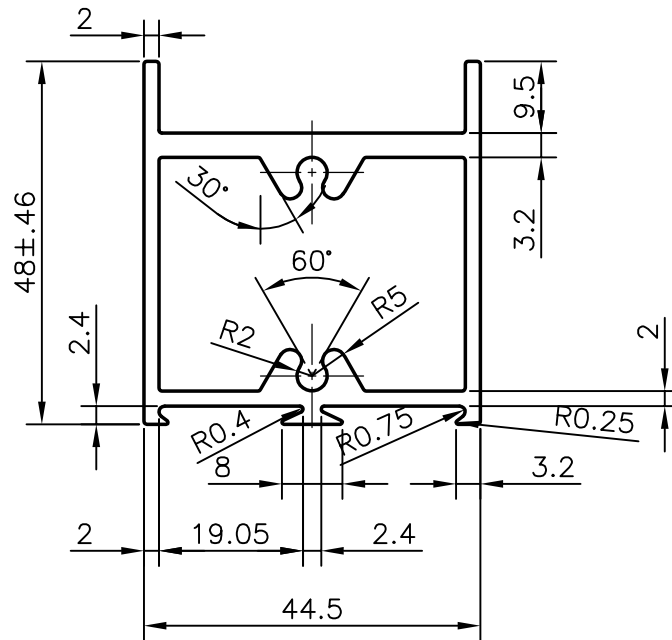

GENERAL WALL THICKNESS = 2.0 mm

JINDAL ALUMINIUM LTD.

BANGALORE-560073

NAME

DATE

DRAWN

R.D.Sharma

12-02-98

CHECKED

APPROVED

1. ALL DIMENSIONS ARE IN mm.
 2. ROUND OFF ALL SHARP CORNERS WITH 0.4 mm.
 3. TOLERANCES WILL BE AS PER IS: 3965-1969 ,UNLESS OTHERWISE SPECIFIED

PARTY'S NAME

GENERAL CATEGORY

SCALE

1:1

PARTY'S DRAWING No.

3004

WEIGHT kg/m

1.342

ALLOY & TEMPER

HE9 WP

SECTION No.

19520

LENGTH

3658 mm.

DRAWING No.

DESCRIPTION

DOOR TOP SECTION

19520