

4552

10544

19528

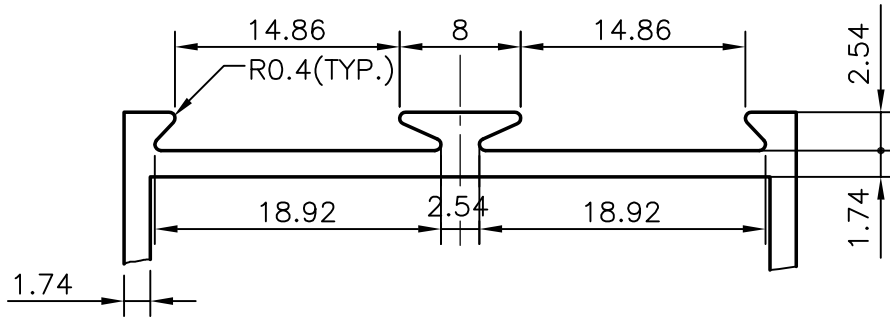

DETAIL AT "A"

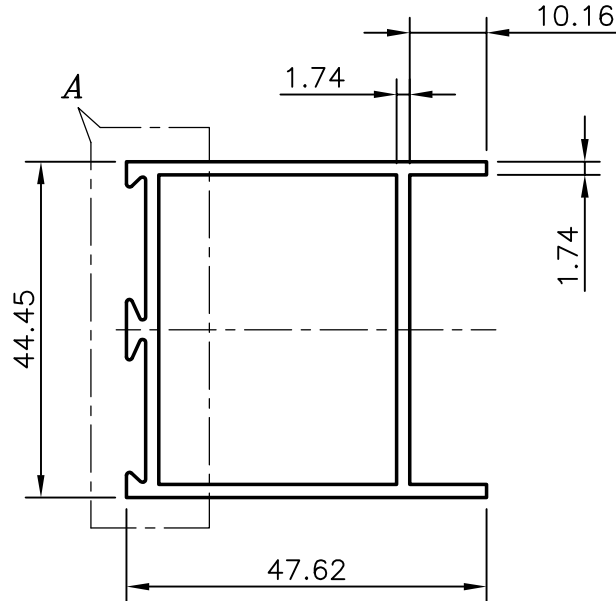

1. NO. OF PIECES IN 100 kgs.:— 31
2. GENERAL WALL THICKNESS:— 1.74 mm.



SYMBOL OF QUALITY
AN ISO 9001 COMPANY

JINDAL ALUMINIUM LTD.
BANGALORE-560073 (INDIA)

	NAME	DATE
DRAWN	PRASANN.H	17-10-2007
CHECKED		
APPROVED		

1. ALL DIMENSIONS ARE IN mm.
2. ROUND OFF ALL SHARP CORNERS WITH 0.40 mm.
3. TOLERANCES WILL BE AS PER IS:6477-1983 UNLESS OTHERWISE SPECIFIED

SCALE	1:1
AREA mm ²	326.556
PERIMETER mm.	225.66
WEIGHT kg/m	0.881

PARTY'S NAME	—	DRAWING No.	4552	SECTION No.	4552
PARTY'S DRAWING No.	—		10544		10544
ALLOY & TEMPER	HE9 WP		19528		19528
DESCRIPTION	DOOR SECTION				