

4553

10573

19529

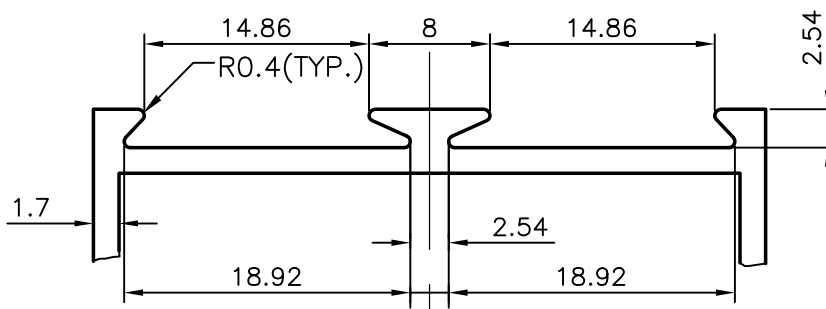

DETAIL AT "X"

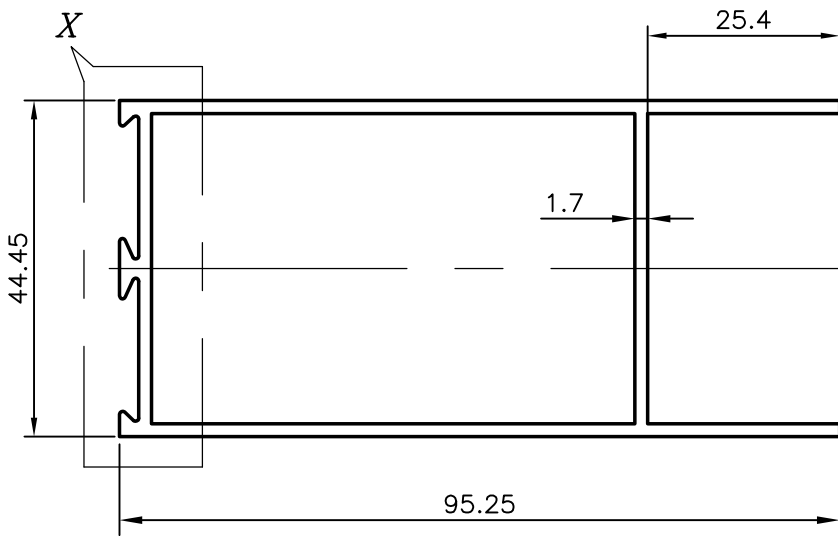

NO. OF PIECES IN 100 kgs = 21 (APPROXIMATE)

GENERAL WALL THICKNESS = 1.7mm



SYMBOL OF QUALITY
AN ISO 9001 COMPANY

JINDAL ALUMINIUM LTD.
BANGALORE-560073 (INDIA)

		NAME	DATE
DRAWN		RAGHAVENDRA	30-10-2006
CHECKED			
APPROVED			
SCALE		1:1	
AREA mm ²		481.886	
PERIMETER mm.		351.4	
WEIGHT kg/m		1.301	
		DRAWING No.	SECTION No.
		4553	4553
		10573	10573
		19529	19529

1. ALL DIMENSIONS ARE IN mm.
2. ROUND OFF ALL SHARP CORNERS WITH 0.40 mm.
3. TOLERANCES WILL BE AS PER IS:6477-1983 UNLESS OTHERWISE SPECIFIED

PARTY'S NAME	-
PARTY'S DRAWING No.	-
ALLOY & TEMPER	HE9 WP
DESCRIPTION	DOOR SECTION