

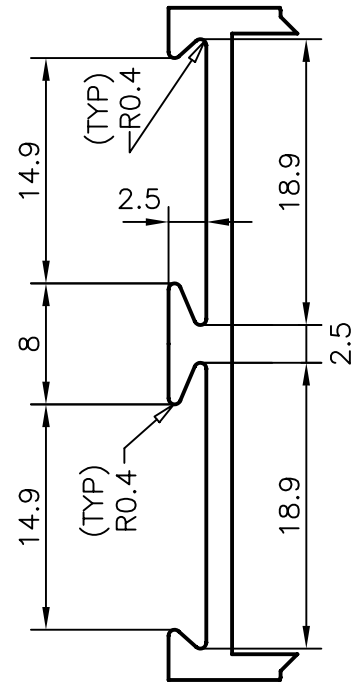

4565
10567
19535

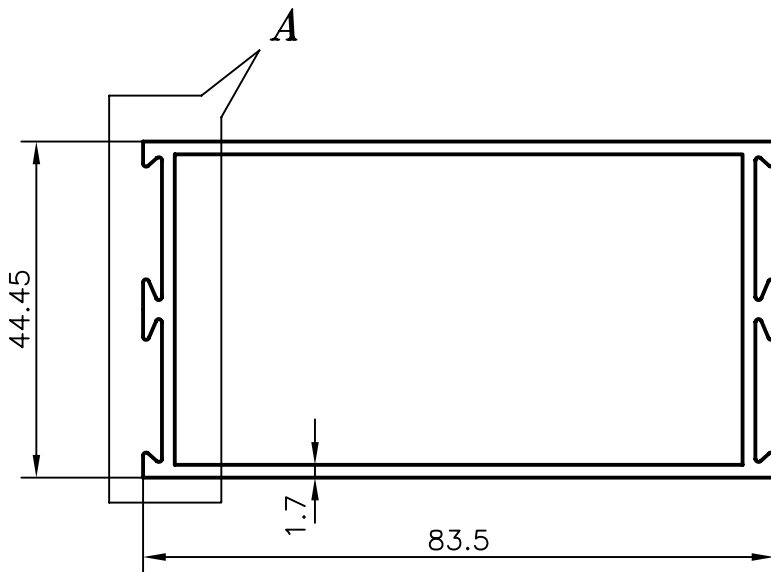

**A** (2:1)

1. GENERAL WALL THICKNESS :- 1.70 mm.
2. No. OF PIECES IN 100 kgs :- 22 (AVERAGE)

 SYMBOL OF QUALITY AN ISO 9001 COMPANY	<b>JINDAL ALUMINIUM LTD.</b> BANGALORE-560073 (INDIA)		NAME	DATE
		DRAWN	J.P.KAUSHIK	12-09-2005
		CHECKED		
		APPROVED		
1. ALL DIMENSIONS ARE IN mm. 2. ROUND OFF ALL SHARP CORNERS WITH 0.40 mm. 3. TOLERANCES WILL BE AS PER IS:6477-1983 UNLESS OTHERWISE SPECIFIED		SCALE		1:1
		AREA mm <sup>2</sup>		459.72
		PERIMETER mm.		297.736
		WEIGHT kg/m		1.243
PARTY'S NAME	-	DRAWING No.	SECTION No.	
PARTY'S DRAWING No.	-	4565	4565	
ALLOY & TEMPER	HE9 WP	10567	10567	
		19535	19535	
DESCRIPTION	DOOR SECTION			