

4575 ISSUE-2

10574

19540 ISSUE-2

DETAIL OF "A"
SCALE 2:1

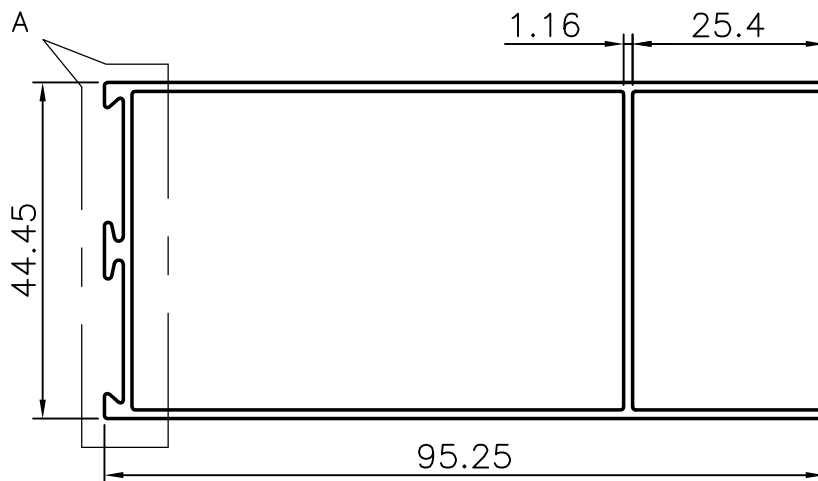
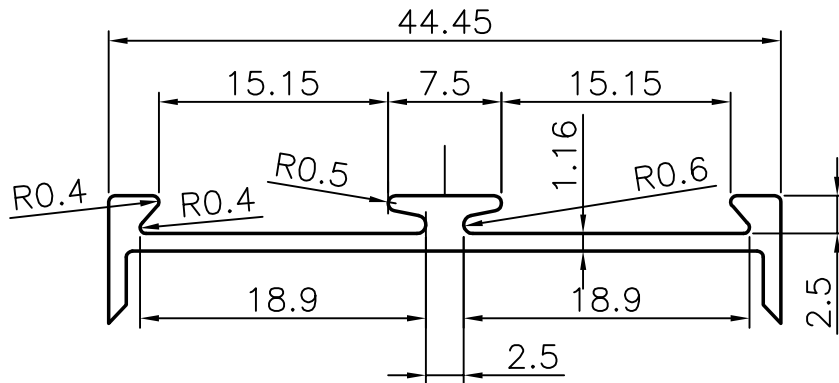

GENERAL WALL THICKNESS = 1.16 mm
3658 mm LONG PIECES IN 100 kgs:- 30 (AVERAGE)



SYMBOL OF QUALITY
AN ISO 9001 COMPANY

JINDAL ALUMINIUM LTD.
BANGALORE-560073 (INDIA)

	NAME	DATE
DRAWN	PRASANN.H	09-01-2007
CHECKED		
APPROVED		

SCALE	1:1
AREA mm ²	338.543
PERIMETER mm.	349.116
WEIGHT kg/m	0.911

DRAWING No.	SECTION No.
4575 ISSUE-2	-
10574	10574
19540 ISSUE-2	19540 ISSUE-2

4575 ISSUE-2	-
10574	10574
19540 ISSUE-2	19540 ISSUE-2

1. ALL DIMENSIONS ARE IN mm.
2. ROUND OFF ALL SHARP CORNERS WITH 0.4 mm.
3. TOLERANCES WILL BE AS PER IS:6477-1983 UNLESS OTHERWISE SPECIFIED

PARTY'S NAME	GENERAL CATEGORY

PARTY'S DRAWING No.	
NIL	

ALLOY & TEMPER	
HE9 WP	

DESCRIPTION	
DOOR SECTION	