

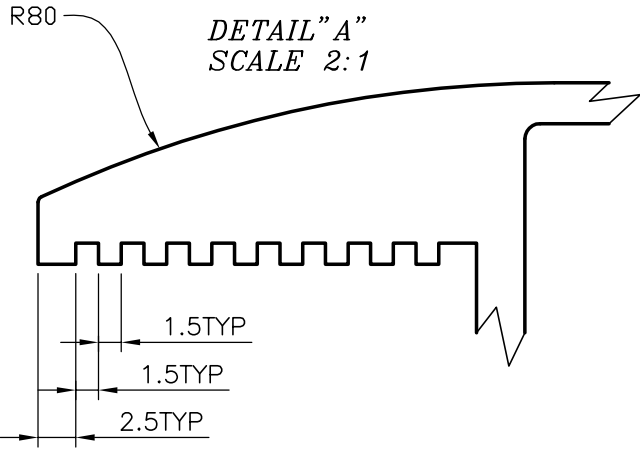

4586
10648
19546

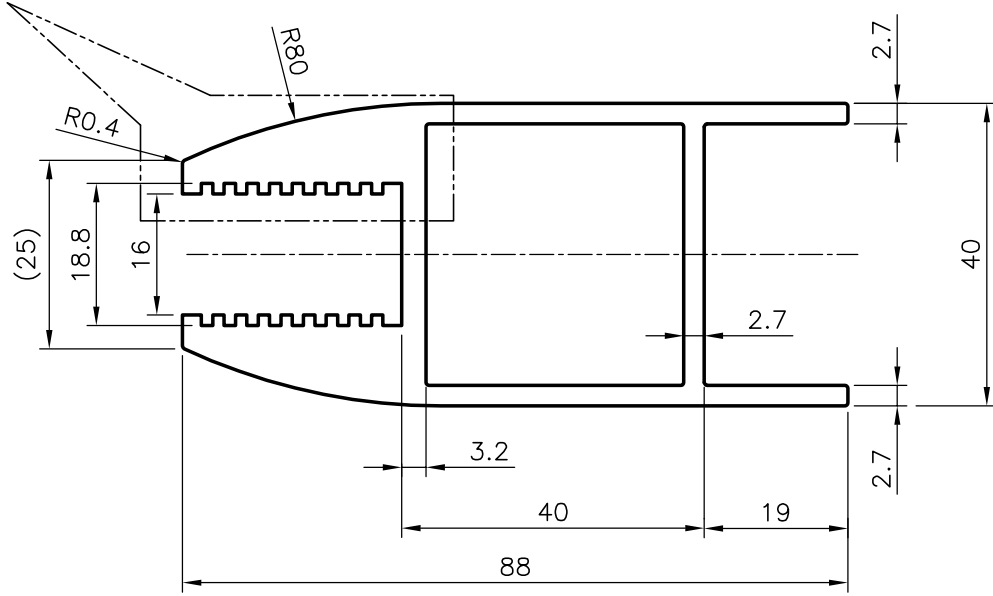

DETAIL "A"



3658 mm, LONG PIECES IN 100 Kgs = 10 (AVERAGE)

 SYMBOL OF QUALITY AN ISO 9002 COMPANY	JINDAL ALUMINIUM LTD. BANGALORE-560073 (INDIA)	NAME		DATE
		DRAWN	RAGHAVENDRA	02-05-2004
1. ALL DIMENSIONS ARE IN mm. 2. ROUND OFF ALL SHARP CORNERS WITH 0.40 mm. 3. TOLERANCES WILL BE AS PER IS:6477-1983 UNLESS OTHERWISE SPECIFIED		CHECKED		
		APPROVED		
PARTY'S NAME —		SCALE		1:1
		AREA mm ²		1007.68
PARTY'S DRAWING No. —		PERIMETER mm.		388.229
		WEIGHT kg/m		2.725
ALLOY & TEMPER HE9 WP		DRAWING No.		SECTION No.
		4586		4586
DESCRIPTION ARCHITECTURAL SECTION		10648		10648
		19546		19546