

4587

10506

19547

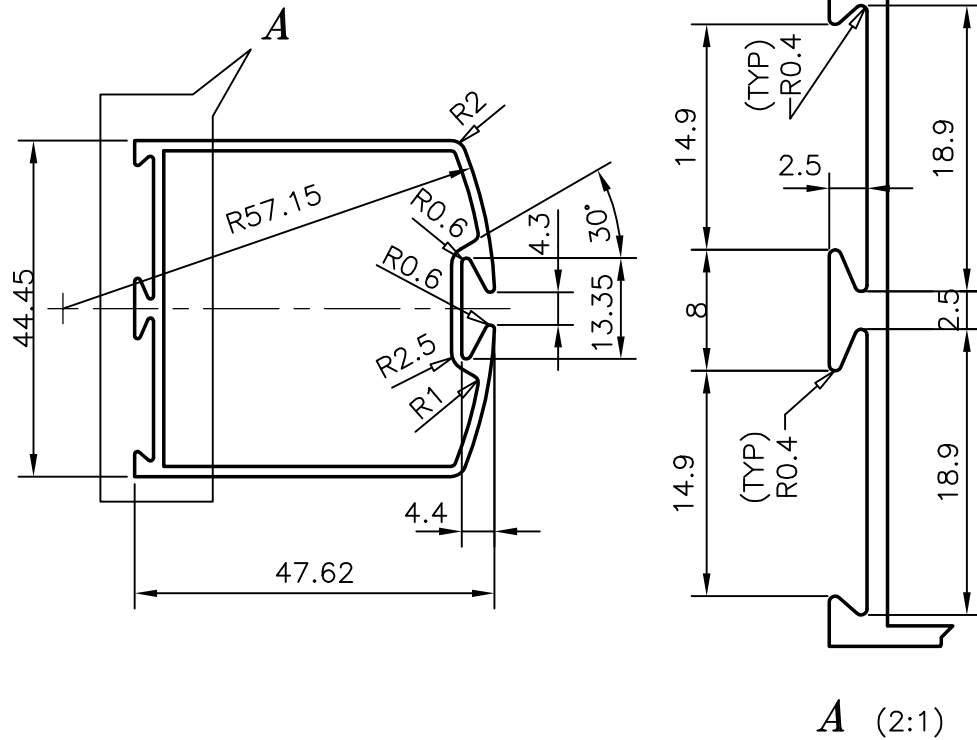

1. GENERAL WALL THICKNESS :- 1.35 mm.
2. NO. OF PIECES IN 100 kgs :- 36 (AVERAGE)



SYMBOL OF QUALITY
AN ISO 9002 COMPANY

JINDAL ALUMINIUM LTD.
BANGALORE-560073 (INDIA)

	NAME	DATE
DRAWN	J.P.KAUSHIK	12-09-2005
CHECKED		
APPROVED		

1. ALL DIMENSIONS ARE IN mm.
2. ROUND OFF ALL SHARP CORNERS WITH 0.40 mm.
3. TOLERANCES WILL BE AS PER IS: 6477-1983 UNLESS OTHERWISE SPECIFIED

SCALE	1:1
AREA mm ²	281.155
PERIMETER mm.	218.586
WEIGHT kg/m	0.759

PARTY'S NAME	GENERAL CATEGORY	DRAWING No.	SECTION No.
PARTY'S DRAWING No.	-	4587	4587
ALLOY & TEMPER	HEP WP	10506	10506
		19547	19547
DESCRIPTION	DOOR VERTICAL		