

4588

10535

19548

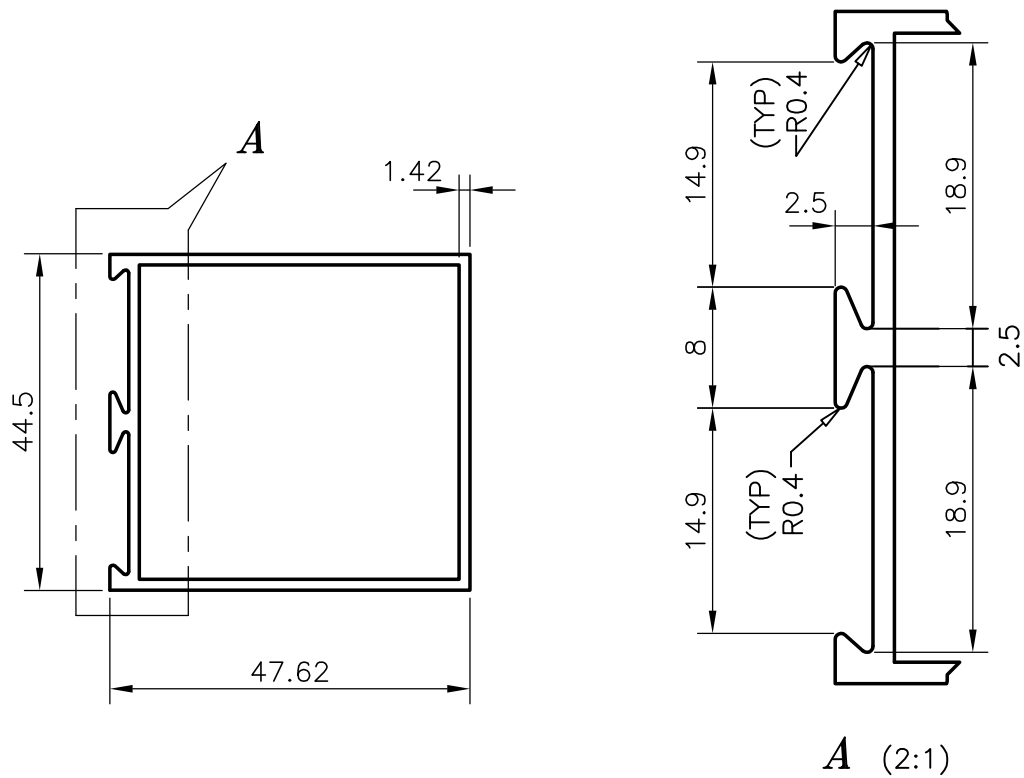

1. GENERAL WALL THICKNESS :- 1.42 mm.
2. NO. OF PIECES IN 100 kgs :- 37 (AVERAGE)



SYMBOL OF QUALITY
AN ISO 9002 COMPANY

JINDAL ALUMINIUM LTD.
BANGALORE-560073 (INDIA)

	NAME	DATE
DRAWN	J.P.KAUSHIK	12-09-2005
CHECKED		
APPROVED		

1. ALL DIMENSIONS ARE IN mm.
2. ROUND OFF ALL SHARP CORNERS WITH 0.40 mm.
3. TOLERANCES WILL BE AS PER IS:6477-1983 UNLESS OTHERWISE SPECIFIED

SCALE	1:1
AREA mm ²	272.938
PERIMETER mm.	205.058
WEIGHT kg/m	0.737

PARTY'S NAME	GENERAL CATEGORY	DRAWING No.	
PARTY'S DRAWING No.	NIL	4588	4588
ALLOY & TEMPER	HEP WP	10535	10535
		19548	19548
DESCRIPTION	DOOR SECTION		