

4591

10568

19551

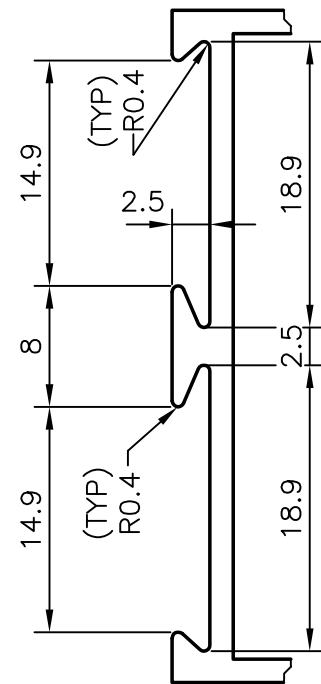
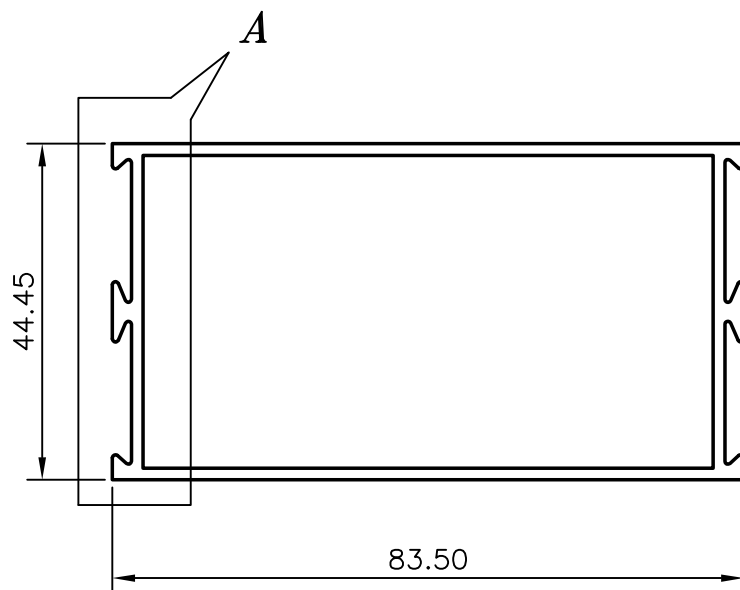

A (2:1)

1. GENERAL WALL THICKNESS :- 1.54 mm.
2. NO. OF PIECES IN 100 kgs :- 24 (AVERAGE)

JINDAL ALUMINIUM LTD. BANGALORE-560073			NAME	DATE
		DRAWN	R.D.Sharma	18-03-98
1. ALL DIMENSIONS ARE IN mm. 2. ROUND OFF ALL SHARP CORNERS WITH 0.4 mm. 3. TOLERANCES WILL BE AS PER IS:6477-1983 ,UNLESS OTHERWISE SPECIFIED		CHECKED		
		APPROVED		
PARTY'S NAME	GENERAL CATEGORY	SCALE		1:1 & 2:1
PARTY'S DRAWING No.	NIL	WEIGHT kg/m		1.139
ALLOY & TEMPER	HE9 WP	SECTION No.		19551
LENGTH	3658 mm.	DRAWING No.		
DESCRIPTION	DOOR SECTION	19551		