

4595  
10502  
19554

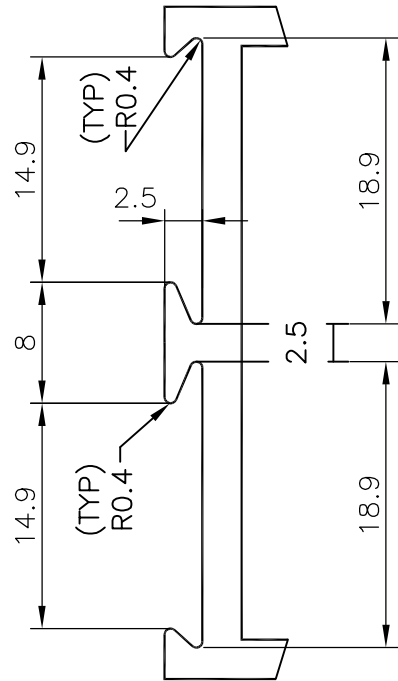
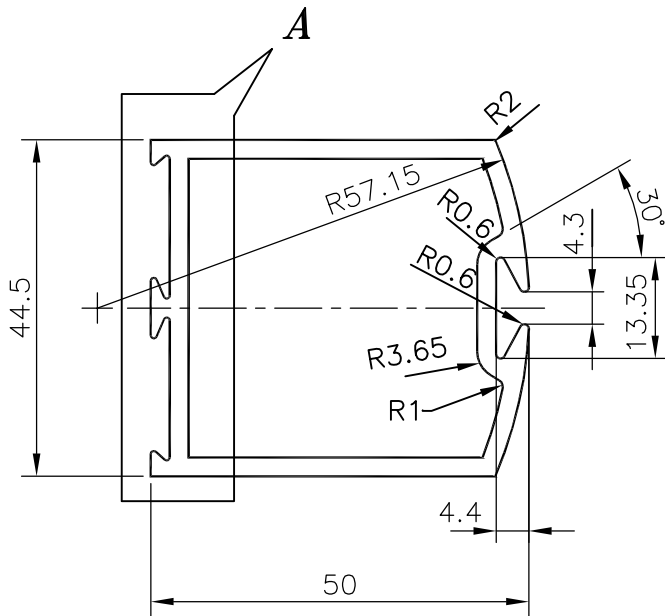

**DETAILS - A**  
(2:1)

GENERAL WALL THICKNESS :- 2.5 mm.

**JINDAL ALUMINIUM LTD.**  
**BANGALORE-560073**

1. ALL DIMENSIONS ARE IN mm.
2. ROUND OFF ALL SHARP CORNERS WITH 0.4 mm.
3. TOLERANCES WILL BE AS PER IS: 6477-1983 ,UNLESS OTHERWISE SPECIFIED

PARTY'S NAME		NAME	
		DATE	
GENERAL CATEGORY, CHENNAI MARKET		DRAWN	D.SRIVASTAVA 15.5.98
PARTY'S DRAWING No. NIL		CHECKED	
ALLOY & TEMPER HE9 WP		APPROVED	
LENGTH 3658mm		SCALE	1:1 & 2:1
DESCRIPTION DOOR SECTION		WEIGHT kg/m	1.292
		SECTION No.	19554
		DRAWING No.	19554