

P-2870
S554
2908
10612
19557

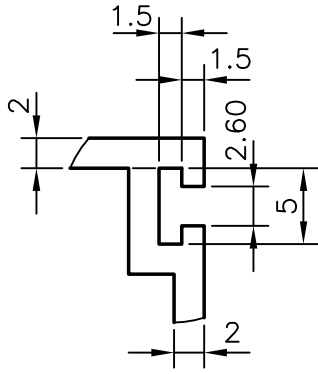

**DETAIL AT 'A'**

(2:1)

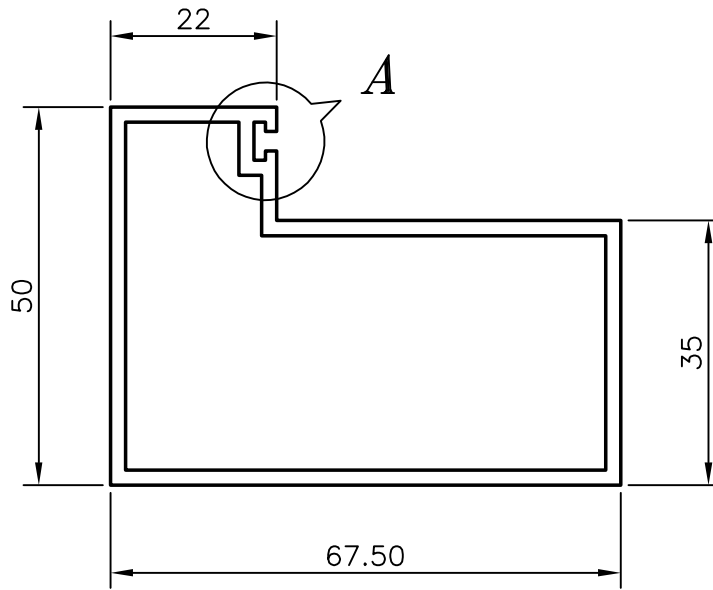

GENERAL WALL THICKNESS:-2 mm.

 SYMBOL OF QUALITY AN ISO 9002 COMPANY	<b>JINDAL ALUMINIUM LTD.</b> BANGALORE-560073 (INDIA)	NAME	DATE
		DRAWN	R.D.Sharma 06-08-2000
1. ALL DIMENSIONS ARE IN mm. 2. ROUND OFF ALL SHARP CORNERS WITH 0.40 mm. 3. TOLERANCES WILL BE AS PER IS 6477-1983 UNLESS OTHERWISE SPECIFIED		CHECKED	
		APPROVED	
		SCALE	1:1
PARTY'S NAME	RADHA SOAMI SATSANG BEAS, BEAS.	WEIGHT kg/m	1.248
PARTY'S DRAWING No.	SKETCH NO. - 1 (B.M. 20006) (OLD)	SECTION No.	19557
ALLOY & TEMPER	HE9 WP	DRAWING No.	
DESCRIPTION	DOOR FRAME SINGLE REBATE	19557	