

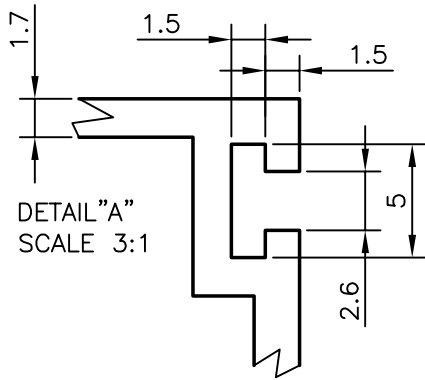

2909
10613
19558

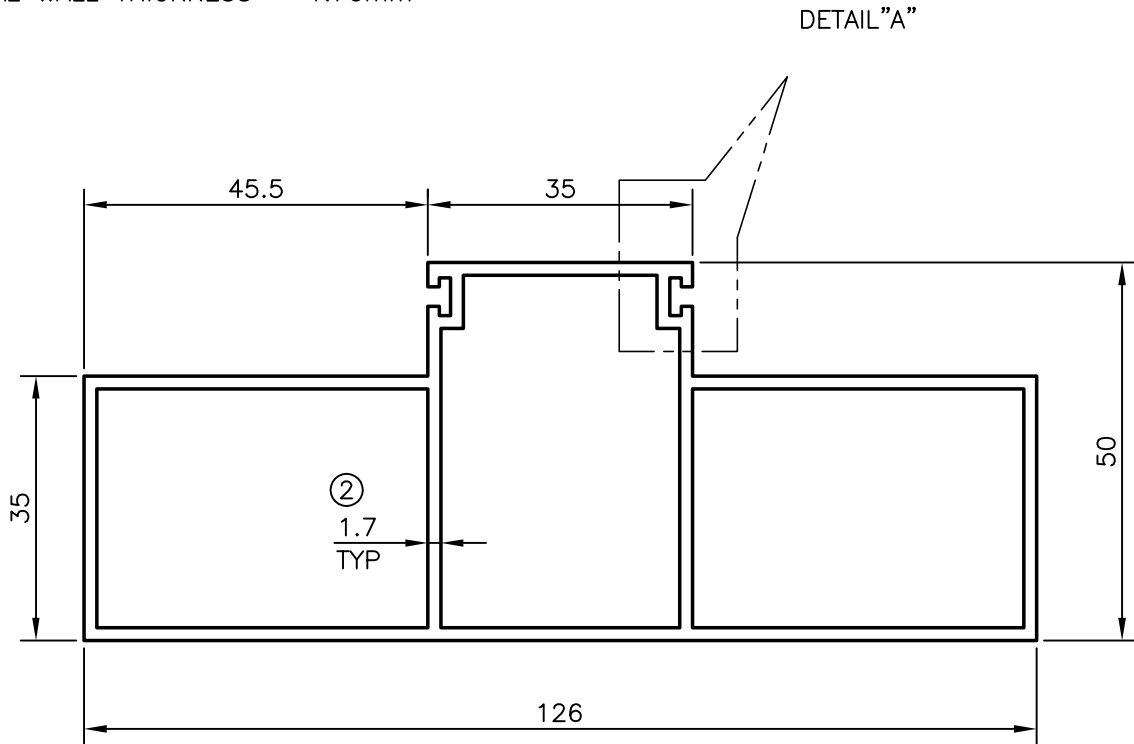

GENERAL WALL THICKNESS = 1.70mm



ISSUE-2 CENTRE RIBS ADDED
 WALL THICKNESS CHANGED FROM 2.0 TO 1.7mm
 WEIGHT ALSO CHANGED FROM 1.909kg/M TO 1.926kg/M

 SYMBOL OF QUALITY AN ISO 9001 COMPANY	JINDAL ALUMINIUM LTD. BANGALORE-560073 (INDIA)	NAME		DATE
		DRAWN	RAGHAVENDRA	08-06-2007
1. ALL DIMENSIONS ARE IN mm. 2. ROUND OFF ALL SHARP CORNERS WITH 0.40 mm. 3. TOLERANCES WILL BE AS PER IS:6477-1983 UNLESS OTHERWISE SPECIFIED		CHECKED		
		APPROVED		
PARTY'S NAME RADHA SOAMI SATSANG BEAS, BEAS		SCALE		1:1
		AREA mm ²		713.48
PARTY'S DRAWING No. BM-20-007 (OLD)		PERIMETER mm.		373.6
		WEIGHT kg/m		1.926
ALLOY & TEMPER HE9 WP		DRAWING No.		2909
		SECTION No.		-
DESCRIPTION DOOR FRAME DOUBLE REBATE		10613		10613
		19558		19558-ISSUE-2