

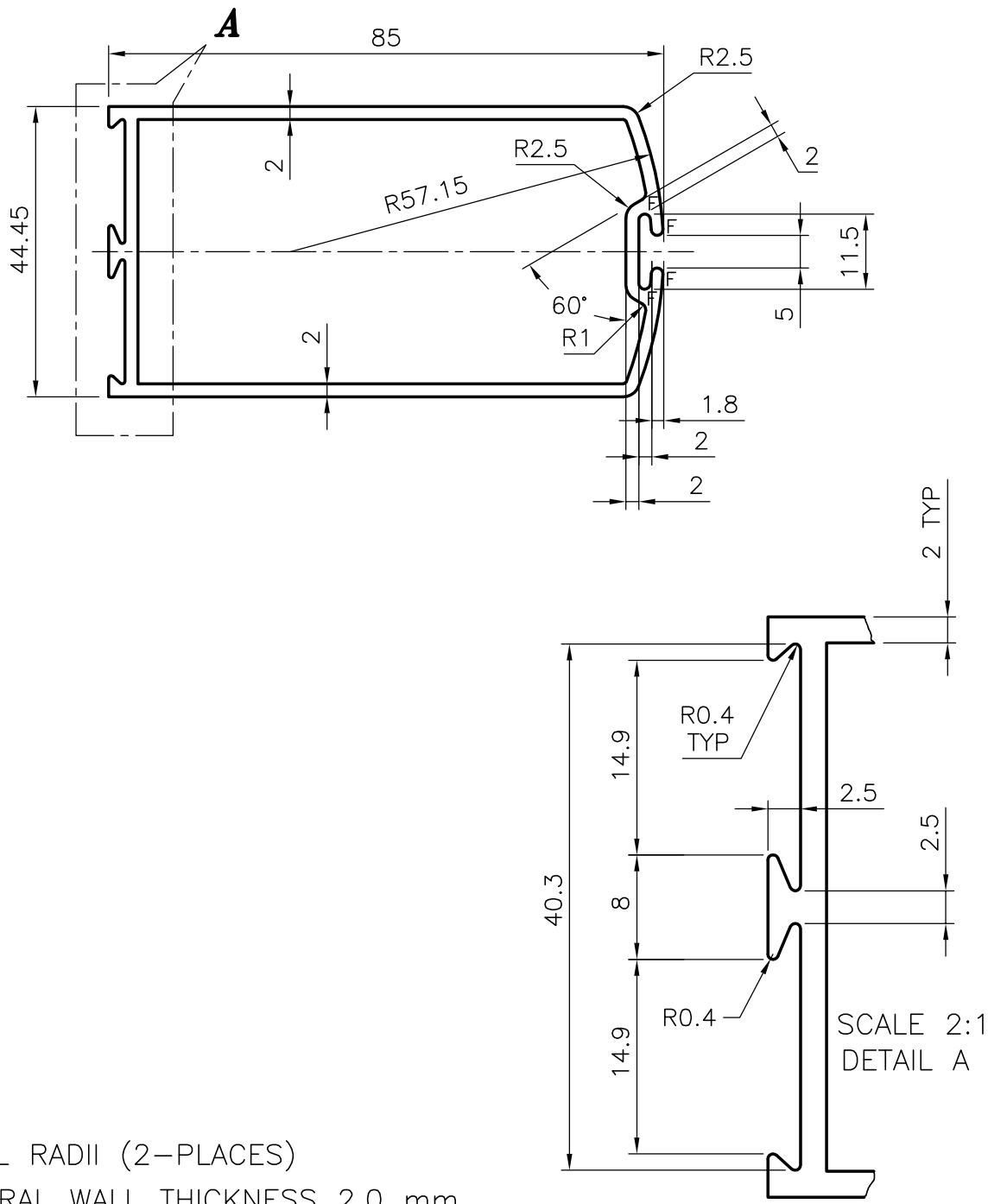

2912
10552
19560



NOTE:
1.F=FULL RADII (2-PLACES)
2. GENERAL WALL THICKNESS 2.0 mm

 SYMBOL OF QUALITY AN ISO 9002 COMPANY	JINDAL ALUMINIUM LTD. BANGALORE-560073 (INDIA)	NAME	DATE
		DRAWN	RANGASWAMY 19-01-01
1. ALL DIMENSIONS ARE IN mm. 2. ROUND OFF ALL SHARP CORNERS WITH 0.40 mm. 3. TOLERANCES WILL BE AS PER IS 6477-1983 UNLESS OTHERWISE SPECIFIED		CHECKED	
		APPROVED	
		SCALE	2:1 & 1:1
PARTY'S NAME	GENERAL CATEGORY., DELHI MARKET	WEIGHT kg/m	1.417
PARTY'S DRAWING No.	AS PER SEC No. 4526 AND SPECIFICATION	SECTION No.	19560
ALLOY & TEMPER	HE9 WP	DRAWING No.	
DESCRIPTION	DOOR SECTION	19560	