

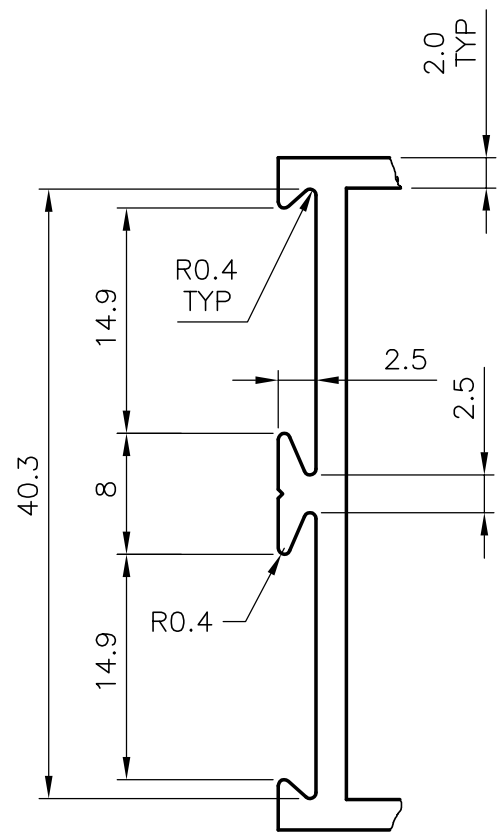

P-3180
2920
10617
19564

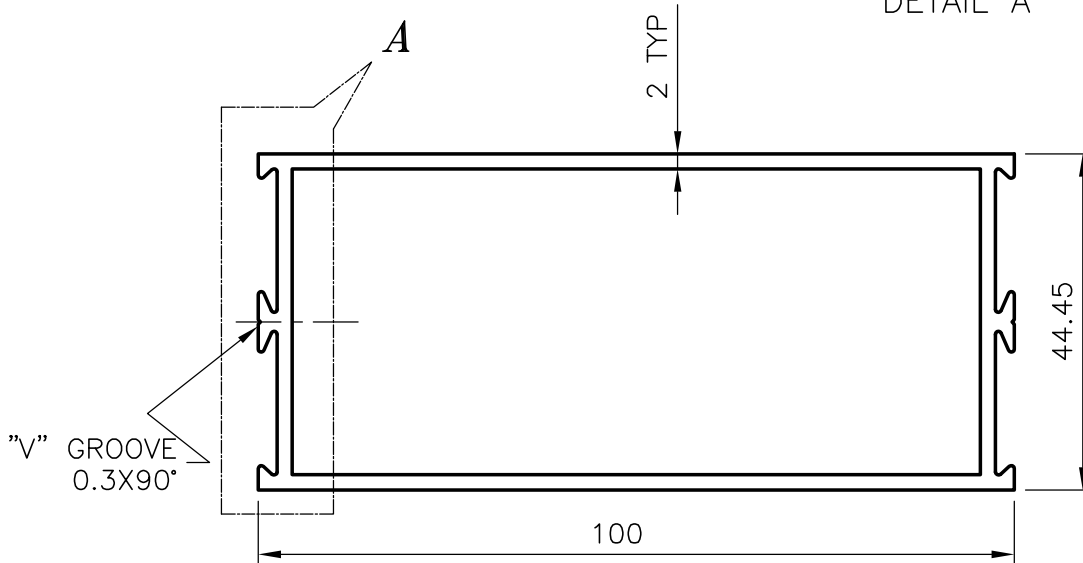

SCALE 2:1
DETAIL A



GENERAL WALL THICKNESS:-2.0 mm

 SYMBOL OF QUALITY AN ISO 9002 COMPANY	JINDAL ALUMINIUM LTD. BANGALORE-560073 (INDIA)	NAME	DATE
		DRAWN	RANGASWAMY 06-04-01
		CHECKED	
1. ALL DIMENSIONS ARE IN mm. 2. ROUND OFF ALL SHARP CORNERS WITH 0.40 mm. 3. TOLERANCES WILL BE AS PER IS:6477-1983 UNLESS OTHERWISE SPECIFIED		APPROVED	
		SCALE	2:1 & 1:1
PARTY'S NAME	GENERAL CATEGORY (CALCUTTA MARKET)	WEIGHT kg/m	1.603
PARTY'S DRAWING No.	AS PER SPECIFICATION (SAMPLE NO 9240)	SECTION No.	19564
ALLOY & TEMPER	HE9 WP	DRAWING No.	
DESCRIPTION	DOOR SECTION	19564	